

MINERTIA MOTOR R SERIES BULLETIN

EXCELLENT PERFORMANCE/SIZE RATIO IN A SMALL PACKAGE

FOR INDUSTRIAL ROBOT DRIVES
TYPE R01□□ TO R40□□

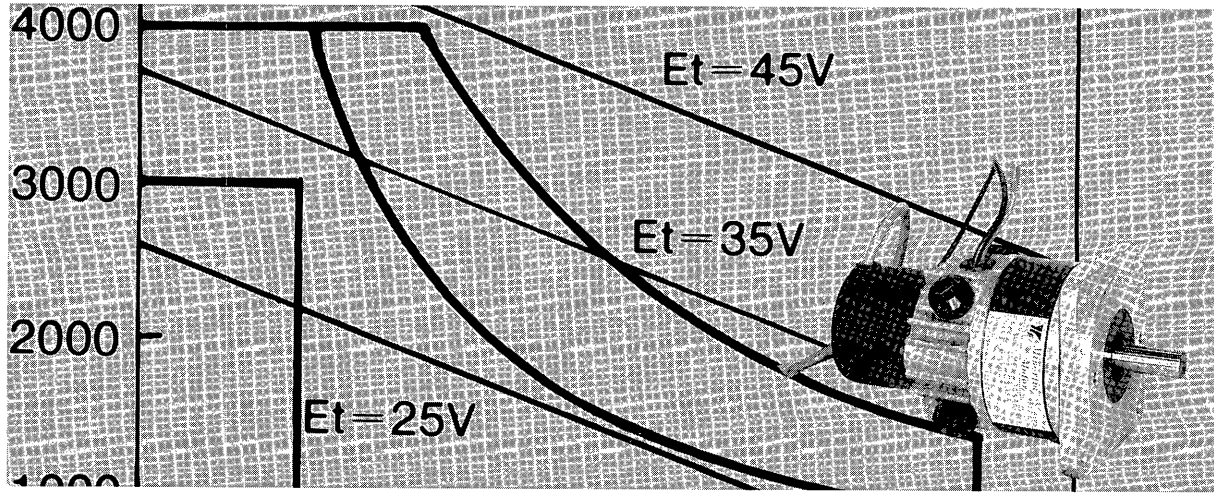

YASKAWA



TSE-C253-20H

Designed to meet the Demands of Robot Applications

R series is a new line introduced for integration into robots as an articulate power drive, or as a drive for insertion machines, IC bonders, or high precision X-Y tables.

R series features compact size, light weight, yet possesses excellent torque/weight and torque/volume ratios in servodrive applications.

FEATURES

- High performance DC servomotor
- Magnetic field formation using rare earth magnet
- Rated speed as high as 3000 rpm
- Compact and light weight
 - Small diameter
 - Short length
- Excellent torque/weight and torque/volume ratios
- Totally-enclosed construction having slot core armature
- Available with optical encoders, feedback units, DC tachometers
- Suitable motor controllers available for special applications
- Unique bearing configuration — no thrust movement of motor shaft

RATINGS AND SPECIFICATIONS

Time rating: Continuous

Insulation: Class B for Type R01SA to R08MB
Class F for Type R40SA and R40MA

Dielectric Strength:
500 VAC for a minute for Type R01SA to R08SA
1000 VAC for a minute for Type R08MB and 40SA
1500 VAC for a minute for Type R40MA

Enclosure: Totally-enclosed self-cooled type

Ambient Temperature: -10°C to +40°C in operation
-20°C to +60°C in storage (no condensation)

Humidity: 35% to 80% RH in operation
10% to 80% RH in storage (no condensation)

Vibration: V-15

Finish in Munsell Notation: N1.5 (Black)

Excitation: Permanent magnet

Mounting: Flange-mounted type

Table 1 Ratings and Specifications

Motor Type	R01SA	R02SA	R02MA	R04SA	R04MA	R08SA	R08MB	R40SA	R40MA	
Peak rated torque oz·in	75	150	250	300	500	750	1250	1190	2140	
Rated torque oz·in	15	30	50	60	100	150	250	450	850	
Torque constant oz·in/A	7.58	8.12	11.5	11.9	16.8	20.2	32.7	51.6	69.0	
Armature winding resistance Ohms (at 25°C)	2.75	1.12	0.94	0.59	0.41	0.41	0.49	0.57	0.34	
Armature inductance mH	1.2	0.9	0.9	0.7	0.6	1.2	2.0	4.0	3.1	
Peak current amps	10	18.8	22.1	25.5	30.1	37.5	38.5	27.6	36.3	
Voltage constant volts/1000 rpm	5.6	6.0	8.5	8.8	12.4	14.9	24.2	38.2	38.2	
Viscous damping coefficient oz·in/1000 rpm	0.42	0.82	1.5	2.2	3.7	3.5	2.5	4.03	7.23	
Friction torque oz·in	0.9	2.4	3.5	3.6	5.1	6.4	8.3	15.5	19.4	
Inertia oz·in·sec ² × 10 ⁻³	0.652	2.22	3.96	13.6	23.7	72.2	118	366	625	
Mechanical time constant millisecc	4.4	5.4	4	8	4.9	10	7.7	11	6.1	
Electrical time constant millisecc	0.44	0.8	0.96	1.2	1.5	2.9	4.1	7.1	9.4	
Power rate kW/sec	2.43	2.86	4.45	1.87	2.97	2.2	3.73	3.94	8.16	
Torque inertia ratio rad/sec ²	23000	13500	12600	4410	4210	2080	2120	1230	1360	
Thermal resistance deg C/watt	3.5	2.33	1.86	1.86	1.55	1.25	1.0	0.8	0.6	
Max temperature rise deg	100	100	100	100	100	100	100	155	155	
Rated speed rpm	3000	3000	3000	3000	3000	3000	3000	2500	2200	
Max safe operating speed rpm	4500	4000	4000	4000	4000	4000	4000	4000	3500	
Max no load speed rpm	5000	5000	5000	5000	5000	5000	5000	4000	3500	
Cooling required cfm, in H ₂ O	Totally-enclosed self-cooled									
Weight lb	0.89	1.77	2.43	3.09	4.86	8.36	11.5	18.1	24.3	

Note: Rated torque is indicated by allowable continuous torque value at ambient temperature 25°C, when the following heat dissipating aluminum

plate is mounted on the motor: 6" × 6" × 1/8" for Type R01, 10" × 10" × 1/4" for Type R02, R04; 12" × 12" × 1/2" for Type R08, R40.

ELECTRIC CHARACTERISTICS

SPEED-TORQUE CHARACTERISTICS

Fig. 1 shows speed-torque characteristics when armature voltage (E_t) and armature current (I_a) are maintained constant.

— = CONTINUOUS DUTY ZONE
 = INTERMITTENT DUTY ZONE
 - - - = RECOMMENDED COMMUTATION LIMIT

(a) Type R01SA

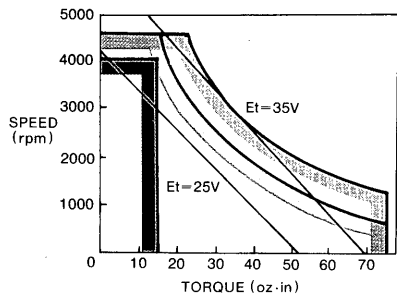

(b) Type R02SA

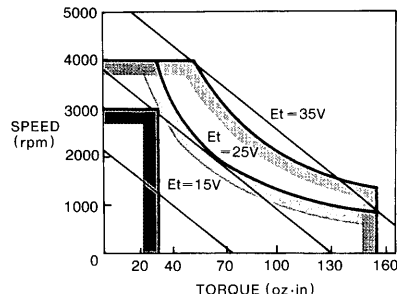

(c) Type R02MA

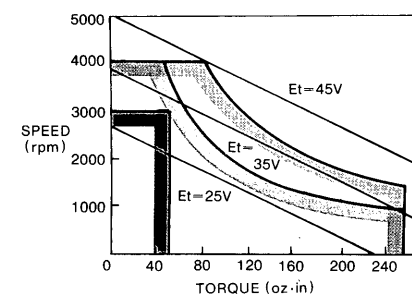

(d) Type R04SA

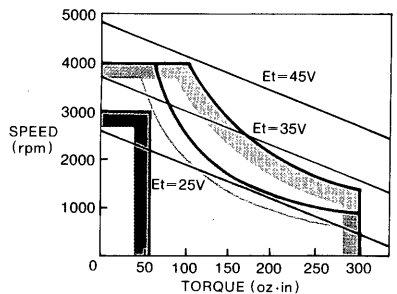

(e) Type R04MA

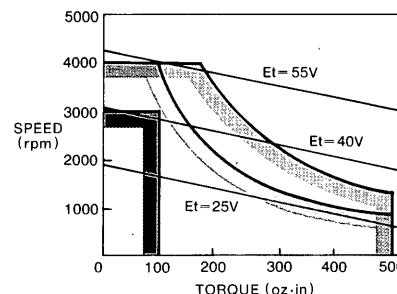

(f) Type R08SA

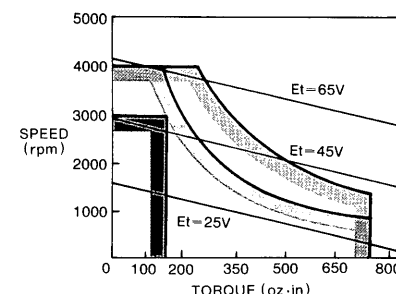

(g) Type R08MB

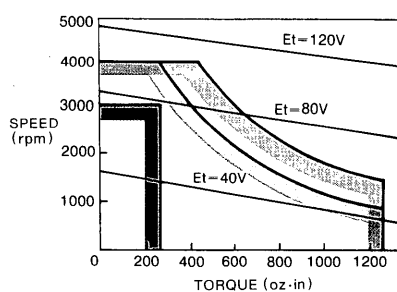

(h) Type R40SA

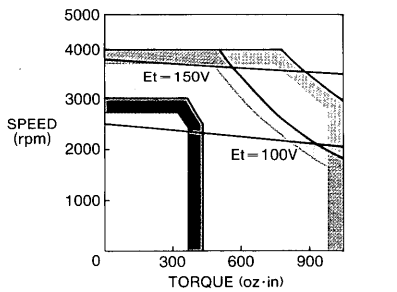

(i) Type R40MA

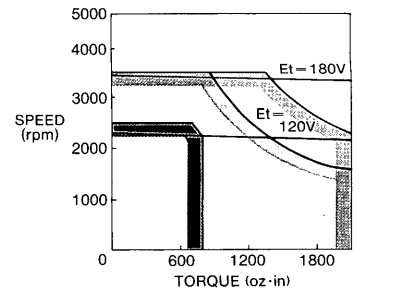
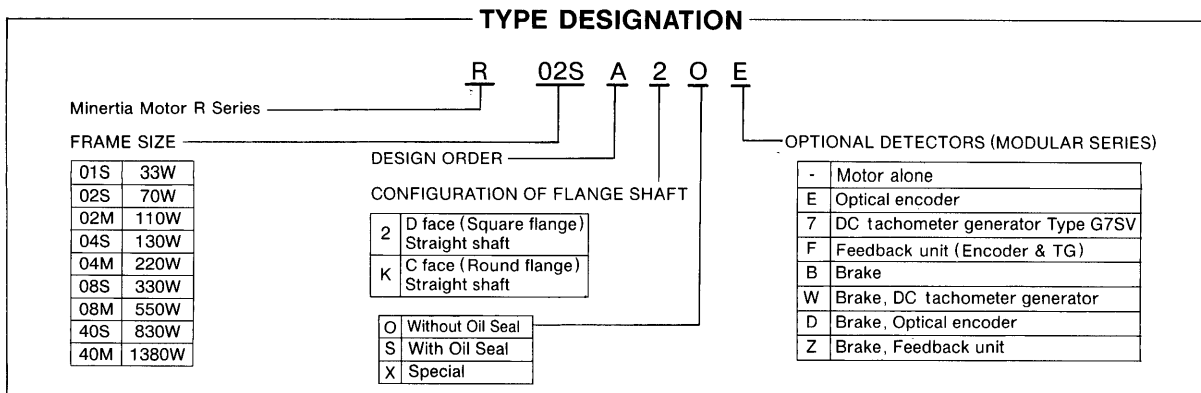

Fig. 1 Speed-Torque Characteristics



STARTING AND OVERLOAD CHARACTERISTICS

At cold condition (A) — Curves are obtained at starting operation when armature temperature is equal to ambient temperature.

At hot condition (B) — Curves obtained when armature temperature is at optimum at the rated operation.

(a) Type R01SA

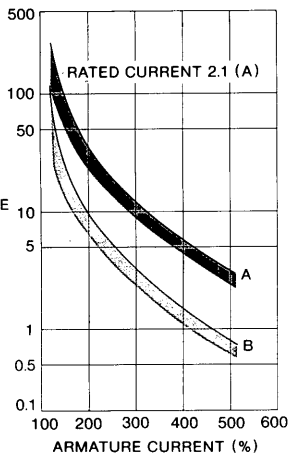

(b) Type R02SA

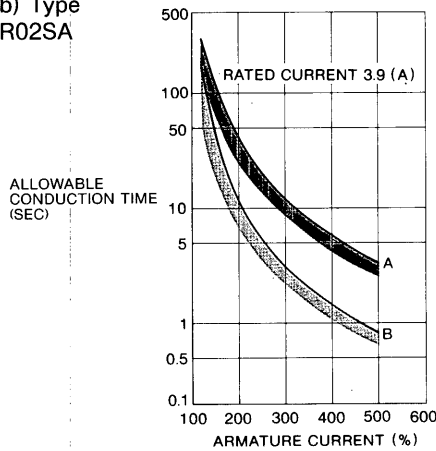

(c) Type R02MA

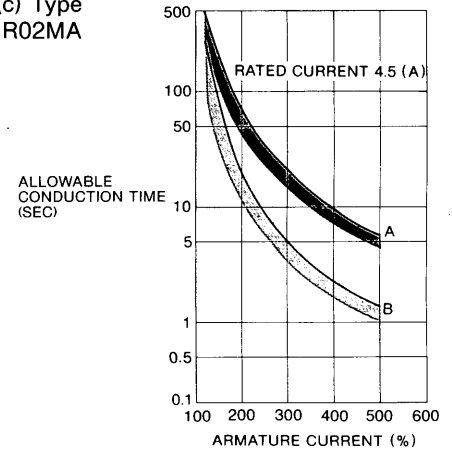

(d) Type R04SA

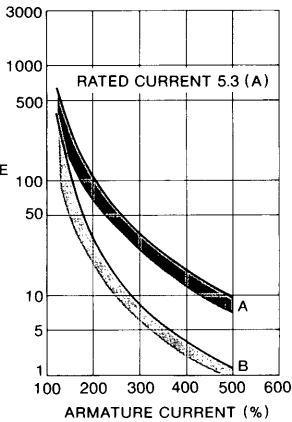

(e) Type R04MA

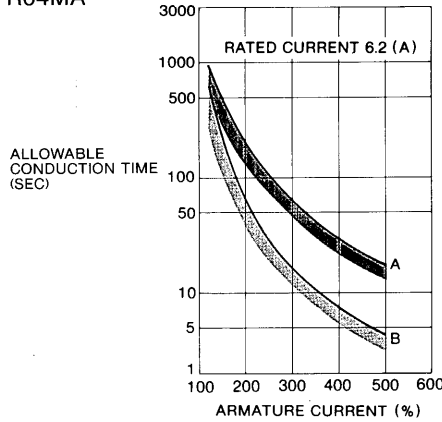

(f) Type R08SA

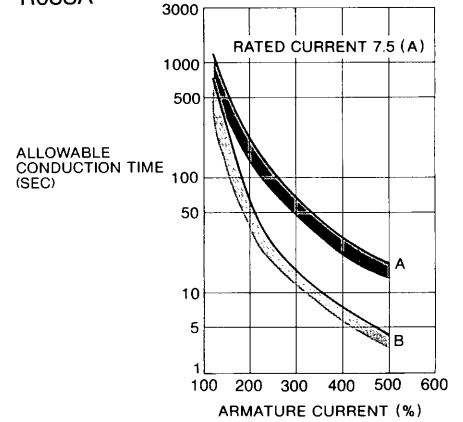

(g) Type R08MB

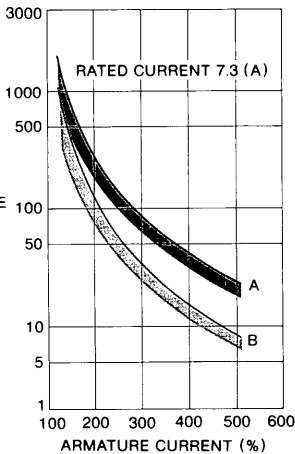

(h) Type R40SA

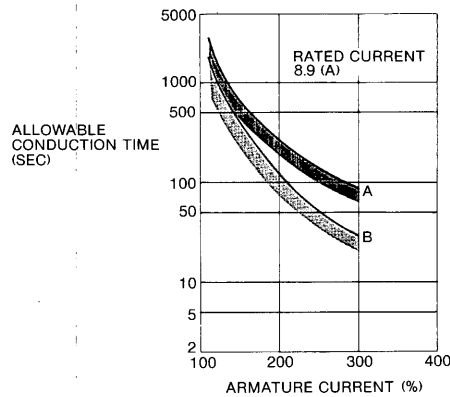

(i) Type R40MA

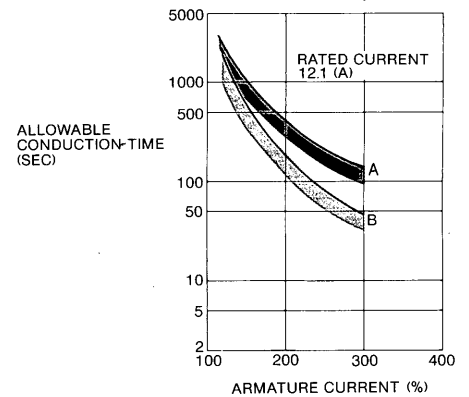

Fig. 2 Starting and Overload Characteristics

GROUNDING MOTOR POWER SUPPLY

When the Minertia Motor R series is operated on DC power obtained by rectifying a single-phase AC current, the circuit should be grounded by the transformer as shown in Fig. 3.

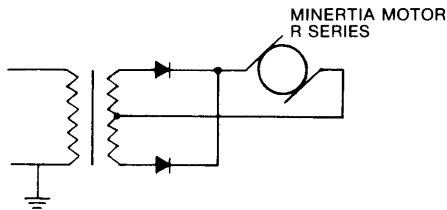

Fig. 3 Grounding of Motor Power Supply

OVERLOAD PROTECTION

It is recommended that the motor be provided with Yaskawa thermal overload relay type RHP-15/F for overload protection.

Table 2 Selection of Thermal Overload Relay

Minertia Motor Type	Rated Current A	Thermal Overload Relay Type RHP
R01SA	2.1	15/2.1F
R02SA	3.9	15/3.9F
R02MA	4.5	15/4.5F
R04SA	5.3	15/5.3F
R04MA	6.2	15/6.2F
R08SA	7.5	15/7.5F
R08MB	7.3	15/7.5F
R40SA	8.9	15/8.3F
R40MA	12.1	15/11.5F

Type	Rated Contact Current A				No. of Thermal Elements	Contact Arrangement	Approx. Weight oz.
	110V	220V	440V	550V			
RHP-15/()	6	3	1.5	1.2	1	1N0NC	2.5

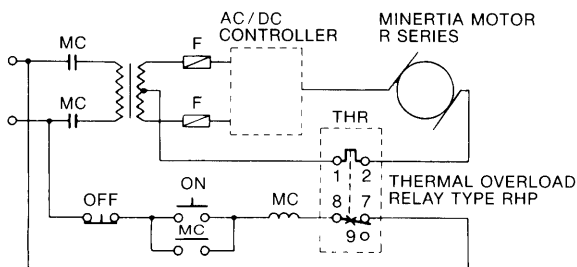

Fig. 4 Connection Diagram of Thermal Overload Relay Type RHP

MECHANICAL CHARACTERISTICS

MECHANICAL STRENGTH

Minertia Motors R series can carry up to 500% of the rated momentary maximum torque at output shaft.

ALLOWABLE THRUST LOAD AND ALLOWABLE EQUIVALENT RADIAL LOAD

Table 3 shows allowable loads according to motor types.

Table 3 Allowable Radial Load and Thrust Load

Minertia Motor Type	Allowable Radial Load (Fr) lb	Allowable Thrust Load (Fs) lb	Reference Diagram in inches
R01SA	8.8	4.4	
R02SA	17.6	8.8	
R02MA	17.6	8.8	
R04SA	33	8.8	
R04MA	33	8.8	
R08SA	55	22	
R08MB	55	22	
R40SA	55	22	
R40MA	55	22	

Note: Radial load and thrust load are the maximum value of total of the load causing from motor torque and the load applying to the shaft externally.

MECHANICAL SPECIFICATIONS

Table 4 Mechanical Specifications in inches

Accuracy (T.I.R.)*	Reference Diagram
Flange surface perpendicular to shaft (A)	
Flange diameter concentric to shaft (B)	
Shaft run out (C)	

* T.I.R. (Total Indicator Reading)

DIRECTION OF ROTATION

Minertia Motor R series rotates counterclockwise viewed from drive end when lead connections are: red lead (+: plus); black lead (-: minus).

IMPACT RESISTANCE

Motor Only

When mounted horizontally and exposed to vertical shock impulses, the motor can withstand up to three impacts with impact acceleration of 50 G.

With Optical Encoder

With motor mounted horizontally and exposed to vertical shock impulses, the motor can withstand up to two impacts with impact acceleration of 10 G.

VIBRATION RESISTANCE

With motor mounted horizontally, the motor can withstand the vibration (vertical, lateral, axial) with vibration acceleration of 2.5 G.

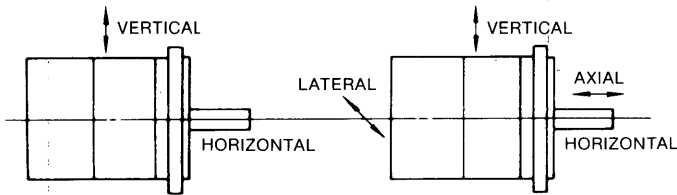

VIBRATION CLASS

Vibration of the motor running at no load is V-15 or below. (amplitude 1.5 micron meter maximum p-p)

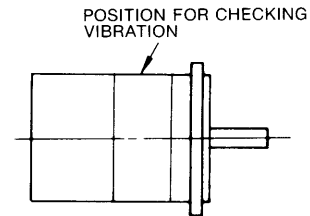

Fig. 5 Impact Resistance

Fig. 6 Vibration Resistance

Fig. 7

MODIFICATIONS

OPTIONS

Type of Shaft Extension

Recommended modification of motor shaft extension is shown in Table 5.

Table 5 Type of Shaft Extension

Dimensions in inches

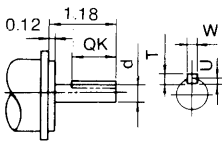
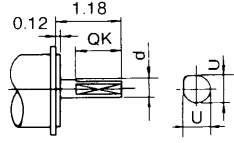
Reference Diagram	With Key					With Flat Key Seat		
	QK	d	T	W	U	QK	d	U
								
								
RO1SA	—	—	—	—	—	0.591	0.0236 ⁺⁰ _{-0.0005}	0.2165
RO2SA	0.787	0.315 ⁰ _{-0.0006}	0.120	0.120	0.0709	0.787	0.315 ⁺⁰ _{-0.0006}	0.2953
RO2MA	0.787	0.315 ⁰ _{-0.0006}	0.120	0.120	0.0709	0.787	0.315 ⁺⁰ _{-0.0006}	0.2953
RO4SA	0.787	0.433 ⁰ _{-0.0006}	0.1575	0.1575	0.0984	0.787	0.315 ⁺⁰ _{-0.0006}	0.3937
RO4MA	0.787	0.433 ⁰ _{-0.0006}	0.1575	0.1575	0.0984	0.787	0.433 ⁺⁰ _{-0.0006}	0.3937
RO8SA	0.787	0.551 ⁰ _{-0.0007}	0.1968	0.1968	0.1181	0.787	0.551 ⁺⁰ _{-0.0007}	0.5118
RO8MB	0.787	0.630 ⁰ _{-0.0007}	0.1968	0.1968	0.1181	0.787	0.630 ⁺⁰ _{-0.0007}	0.5118
R40SA	1.260	0.748 ⁰ _{-0.0008}	0.2362	0.2362	0.138	—	—	—
R40MA	1.260	0.748 ⁰ _{-0.0008}	0.2362	0.2362	0.138	—	—	—

Drip-proof Type

Motor structure of Minertia Motor R series of drip-proof type is as shown below.

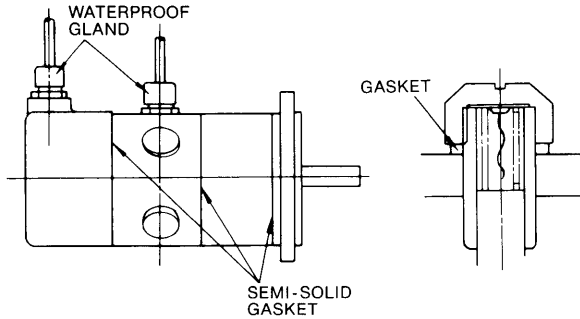

Fig. 8 Drip-proof Enclosure

Caution when operation

- Never expose the motor to water (e.g. heavy rain, flooding, spraying). Protect the motor from corrosive liquids.
- Oil seal will not be provided with the drip-proof type motor. If oil seal is required, it should be ordered in addition to designating drip-proof type.

Connectors and Cables

Connectors and cables can be also specified by the customer. Contact the company representative for the special requirement.

Oil Seals

Life expectancy of oil seal is approximately 5000 hours at rated load and rated speed.

Oil sealed motors should be operated under the following conditions:

- Optimum oil level should be below oil seal lip.
- Oil seal should not be immersed in oil.

Avoid the locations listed below:

- Where corrosive liquids like chemicals and salt water prevail.
- Where explosive gases or corrosive gases like chlorine gas, hydrogen gas, and oxygen gas persist.
- In vacuum or where inert gas exists.

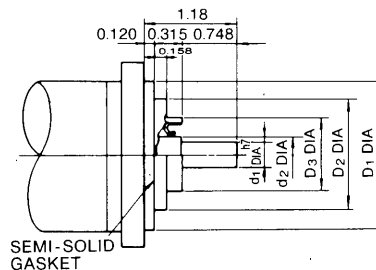

Dimensions in inches

Motor Type	Oil Seal Type	D ₁	D ₂	D ₃	d ₁	d ₂
R01SA□□S□	—	—	—	—	—	—
R02SA□□S□	SB08227 (NOK)*	1.97	1.77	1.10	0.315 ⁺⁰ _{-0.0006}	0.394
R02MA□□S□	SB08227 (NOK)	1.97	1.77	1.10	0.315 ⁺⁰ _{-0.0006}	0.394
R04SA□□S□	SB12257 (NOK)	2.76	2.52	1.57	0.433 ⁺⁰ _{-0.0006}	0.472
R04MA□□S□	SB12257 (NOK)	2.76	2.52	1.57	0.433 ⁺⁰ _{-0.0006}	0.472
R08SA□□S□	SB17287 (NOK)	4.33	3.54	2.56	0.551 ⁺⁰ _{-0.0007}	0.669
R08MB□□S□	SB17287 (NOK)	4.33	3.54	2.56	0.630 ⁺⁰ _{-0.0007}	0.669
R40SA□□S□	SB20307 (NOK)	4.33	3.54	2.56	0.748 ⁺⁰ _{-0.0008}	0.787
R40MA□□S□	SB20307 (NOK)	4.33	3.54	2.56	0.748 ⁺⁰ _{-0.0008}	0.787

*NOK: Nippon Oil Seal Industry Co., Ltd.

MODULAR MINERTIA MOTORS R SERIES

Modular Minertia Motors consist of any combination of Minertia Motor R series with DC tachometer generator, optical encoder, or magnetic brake.

Table 6 List of Options Combined with Minertia Motors R Series

⊙: Standard ○, △: Available on order ×: Not manufactured

Motor Type	Type	7	E	B	F	W	D	Z
	Options	TG	OP	BR	FBU	BR&TG	BR&OP	BR&FBU
R01SAKO	Motor alone	○	○	×	×	×	×	×
R02SA2O	Motor alone	○	○	○	○	△	△	△
R02MA2O	Motor alone	○	○	○	○	△	△	△
R04SA2O	Motor alone	○	○	○	○	△	△	△
R04MA2O	Motor alone	○	○	○	○	△	△	△
R08SA2O	Motor alone	○	○	○	○	△	△	△
R08MB2O	Motor alone	○	○	○	○	△	△	△
R40SA2O	Motor alone	○	○	○	○	△	△	△
R40MA2O	Motor alone	○	○	○	○	△	△	△

Note: For options indicated by △, contact the company representative.
 TG: DC tachometer generator OP: Optical encoder
 BR: Magnetic brake FBU: Feedback unit

Table 7 Applicable Magnetic Brakes and Detectors for Minertia Motors R Series

Motor Type UGRMEM	Magnetic Brake Type	Detector		
		DC Tach-gen	Optical Encoder	Feedback Unit
R02SA2O	MSB / 90-3YM	TG-7SVC	UTOPI- □□□□ SE, UTOPI- □□□□ SC	TFUE- □□□□ SE, TFUE- □□□□ SC
R02MA2O				
R04SA2O	MSB / 90-6.5YM			
R04MA2O				
R08SA2O	SCFB / 90-20YM			
R08MB2O				
R40SA2O	FSB / 90-40			
R40MA2O				

Note: Motor type UGRMEM-R01SA cannot be attached magnetic brake.

With DC Tachometer Generator

DC tachometer generators are available as speed feedback units. Specifications of DC tachometer generators are shown in table below.

Table 8 Specifications of DC Tachometer Generator

Type	G7SVC
Output Voltage	(V/1000 rpm) ± 10 %
Ripple Amplitude	% p-p (at 1000 rpm)
Ripple Frequency	Cycles/rev.
Linearity	% (at 200-4000 rpm)
Direction Deviation	% (at 200-4000 rpm)
Armature Inertia	oz · in · s ² × 10 ⁻³
Armature Resistance	Ω (20°C) ± 10 %
Temperature Coefficient	%/°C
Speed Range	rpm
Max Speed	rpm
Min Load Resistance	kΩ
Insulation Resistance	MΩ
Dielectric Strength	VAC
Ripple Expectancy	H

Note:

- Output voltage is measured across the output terminals.
- Ripple amplitude and linearity are obtained through filter circuit as shown below.

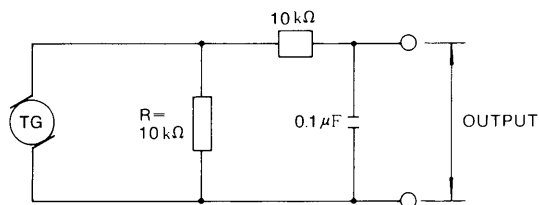

With Optical Encoder

Optical encoders are available as position and speed feedback signals.
(For speed feedback signals, F/V converter should be used.) Specifications are listed in Table 9.

Table 9 Specifications of Optical Encoders

Optical Encoder Type	UTOPI- SE	UTOPI- MAB	UTOPI- MUB
Input Supply Voltage	+5 TO +12VDC ±5%	+ 12 VDC ± 5%	+ 5VDC ± 5%
Current Consumption	150 mA max	150 mA max	
No. of Output Pulses	Type UTOPI-020 200 pulses/rev Type UTOPI-030 300 pulses/rev Type UTOPI-040 400 pulses/rev Type UTOPI-050 500 pulses/rev Type UTOPI-060 600 pulses/rev Type UTOPI-080 800 pulses/rev Type UTOPI-100 1000 pulses/rev Type UTOPI-150 1500 pulses/rev Type UTOPI-200 2000 pulses/rev Type UTOPI-250 2500 pulses/rev	Type UTOPI-040 400 pulses/rev Type UTOPI-050 500 pulses/rev Type UTOPI-060 600 pulses/rev Type UTOPI-080 800 pulses/rev Type UTOPI-100 1000 pulses/rev	
Output Wave Form	Square Wave	Square Wave	
Output Signal Level	V _{OH} : 10V Min at 12V V _{OH} : 4V Min at 5V V _{OL} : 1.5V Max at 12V V _{OL} : 0.4V Max at 5V	V _{OH} : 10V Min V _{OH} : 4V Min V _{OL} : 1.5V Max V _{OL} : 0.4V Max	
Rise Time	1 μs Max.	1 μs Max.	
Fall Time	0.5 μs Max.	0.5 μs Max.	
Output Circuit			
Phase Offset	φ: 25 ± 10 %	φ 25 ± 10 %	
Flutter	2% p-p Max	2% p-p Max	
Pulse Duty Cycle	50 ± 10%	50 ± 10%	
Channel Z Pulse Width	50 ± 10%	50 ± 10%	
Response Frequency	75 kHz	75 kHz	
Illumination Source	LED	LED	
Sensor	Photo diode	Photo diode	
Max Allowable Speed	12,000 rpm	12,000 rpm	
Moment of Inertia	9.9 oz·in·s ² × 10 ⁻⁵	5 oz·in·s ² × 10 ⁻⁵	
Ambient Temperature	0 to + 60°C (in operation), - 20 to + 80°C (at standby)	0 to + 60°C (in operation), - 20 to + 80°C (at standby)	
Humidity	+20 to +80% RH	+20 to +80% RH	
Vibration (in operation)	2.5 G Max	2.5 G Max	

★Lead Identification of Encoders and DC Tachometer Generators

• Type SE, MAB, MUB

	Input/Output	Color	Lead Function
Encoder	Input	Red	+5 VDC or +12 VDC
		Black	0 V
	Output	Blue	Channel A output
		Black	Channel A common
		Yellow	Channel B output
		Black	Channel B common
		Green	Channel Z output
Black	Channel Z common		
DC Tachometer Generator	Output	White	Plus
		Black	Minus

(Signal Wave)

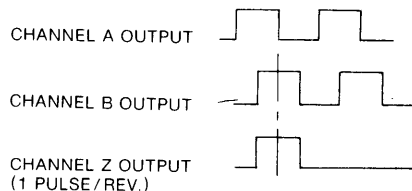

Origin pulse, 1 pulse/rev synchronizes with channel B pulse.

• Type SC (Balanced type line driver)

	Input/Output	Color	Lead Function
Encoder	Input	Red	+5 VDC
		Black	0 V
	Output	Blue	Channel A output
		Black	Channel A output
		Yellow	Channel B output
		Black	Channel B output
		Green	Channel Z output
Black	Channel Z output		
DC Tachometer Generator	Output	White	Plus
		Black	Minus

(Signal Wave)

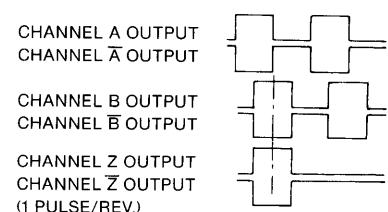

Origin pulse, 1 pulse/rev synchronizes with channel B pulse.

With Feedback Units

Feedback units are available as position and speed detection units. Feedback units for Minertia Motor R series unitized DC tachometer generator and optical encoder. Specifications are listed in Table 10.

Table 10 Specifications of Feedback Unit

	TFUE	SE
	G7SVC (DC tachometer generator)	UTOPI: (Optical encoder) SE
Characteristics	See Table 8.	See Table 9.
Rotor Inertia J ($GD^2/4$)	0.354 oz·in·s ² 10 ⁻³ Max	
Friction Torque	2.09 oz·in·Max	
Filter Circuit	See Table 8.	—

With Magnetic Brakes

Magnetic brakes listed below are not used for stopping, but for holding after coming to a full stop.

Table 11 Specifications of Magnetic Brakes

	Magnetic Brake Type			
	MSB/ 90-3YM	MSB/ 90-6.5YM	SCFB/ 90-20YM	FSB/ 90-40
Input Supply Voltage	90 VDC ± 10 %			
Power Consumption HP	7.4	7.1	14.5	16.8
Braking Torque oz·in	42	90	278	555
Applicable Motor	R02SA	R04SA	R08SA	R40SA
	R02MA	R04MA	R08MB	R40MA
Type	Spring loaded fail-safe type			

MEMO

MOTOR CONTROLLER

For detailed data on Servopack, refer to bulletin, Servopack Type CPCR-FR.

Listed below are Minertia Motors R Series and

Servopack and f/V Converters. f/V converters are to be used only when speed feedback signal must be obtained from optical encoder.

Table 12 Minertia Motors and Applicable Controller Servopack

Minertia Motor Type	Servopack Type CPCR-1	DC Reactor Type	Power Transformer Type GPT-	f/V Converter ² Type JASP-
R01SAKOE	FR01B97-R1S	X-5019(3mH2A)	10042(150 VA)	FV00-000-000
R02SA2OE	FR01B97-R2S	X-3064 (1mH8A)	8570(200 VA)	FV00-000-000
R02SA2OF	FR01B-R2S			—
R02MA2OE	FR01B97-R2M		FV00-000-000	
R02MA2OF	FR01B-R2M		—	
R04MA2OE	FR01B97-R4S		8629(500 VA)	FV00-000-000
R04MA2OF	FR02B-R4S			—
R04MA2OE	FR02B97-R4M			FV00-000-000
R04MA2OF	FR02B-R4M			—
R08SA2OE	FR05C97-R8S	X-5006 (2mH8A)	10017(1 kVA)	FV00-000-000
R08SA2OF	FR05C-R8S			—
R08MB2OE	FR05C97-R8M			FV00-000-000
R08MB2OF	FR05C-R8M			—
R40SA2OE	MR15CY92, 94	X-3056	—	FV00-000-000
R40SA2OF				—
R40MA2OE	MR22CY93, 95	X-3057	—	FV00-000-000
R40MA2OF				—

1 Type Designation of Servopack

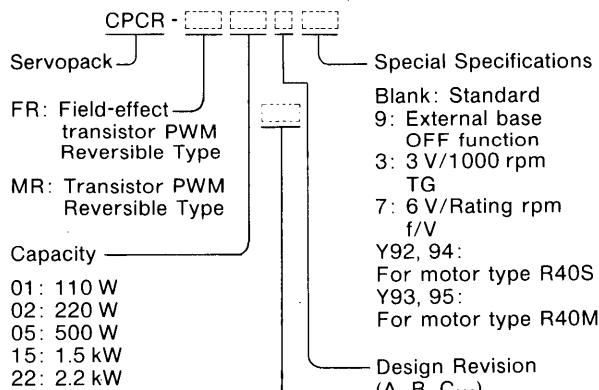

Motor Type

- R1S : Type R01S
- R2S : Type R02S
- R2M : Type R02M
- R4S : Type R04S
- R4M : Type R04M
- R8S : Type R08S
- R8M : Type R08M

2 Specifications of f/V Converter

JASP-FV00-000-000	
Power Supply	+ 12 V ± 1% 110 mA, + 12 V ± 1% 50 mA, + 5 V ± 5% 200mA
Environmental Condition	Operating Temperature 0 to +60°C
	Storing Temperature -20 to +70°C
Input	Humidity 85 % Max (No condensation)
	Frequency 90°C Phase difference 2-Phase pulse 50 kHz Max
	Pulse Voltage 12 V (JASP-FV00 1-000) 5 V (JASP-FV00 2-000)

Contact the company representative.

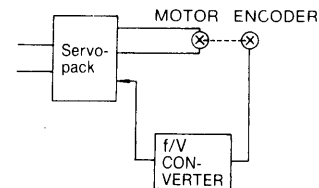

DIMENSIONS in inches

MOTORS ONLY

Type R01

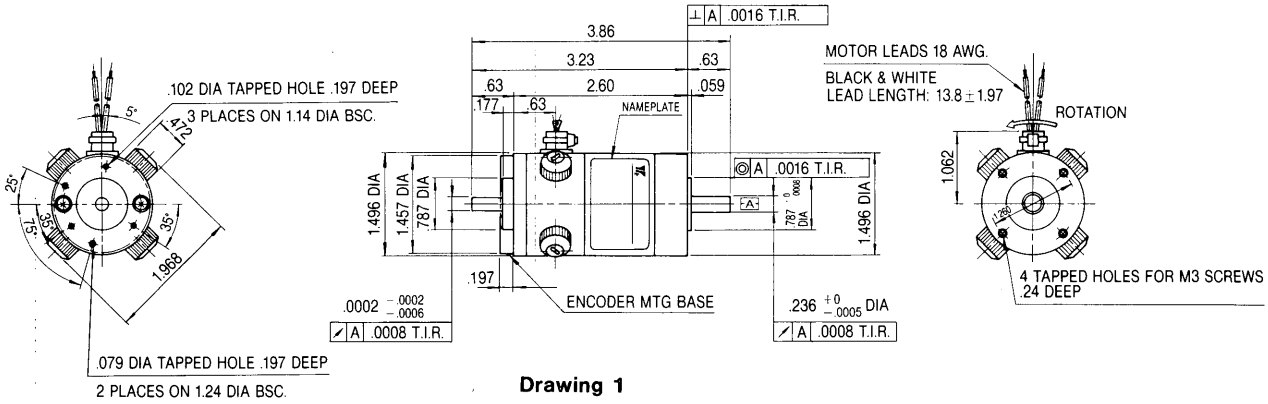

Type R02

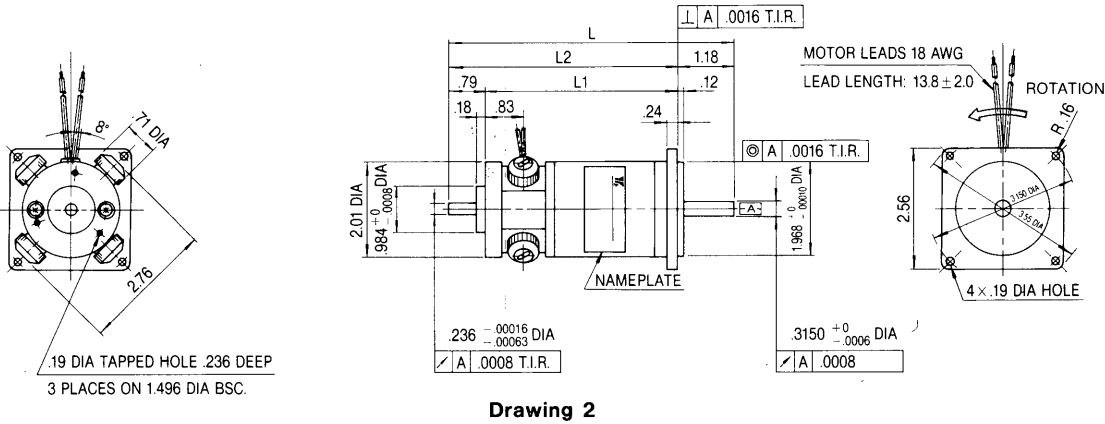

Type R04

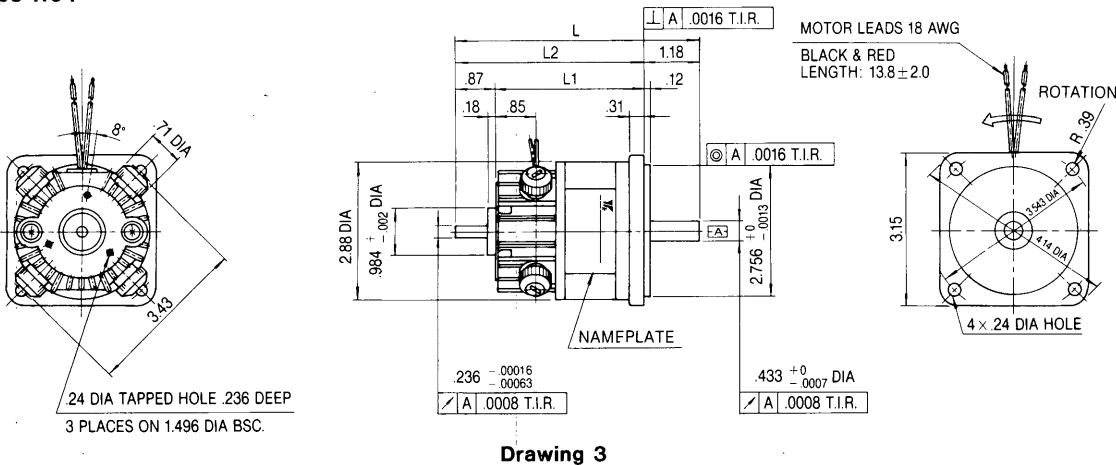

Minertia® Motor R Series

Type R01.000 to R40.000

Type R08

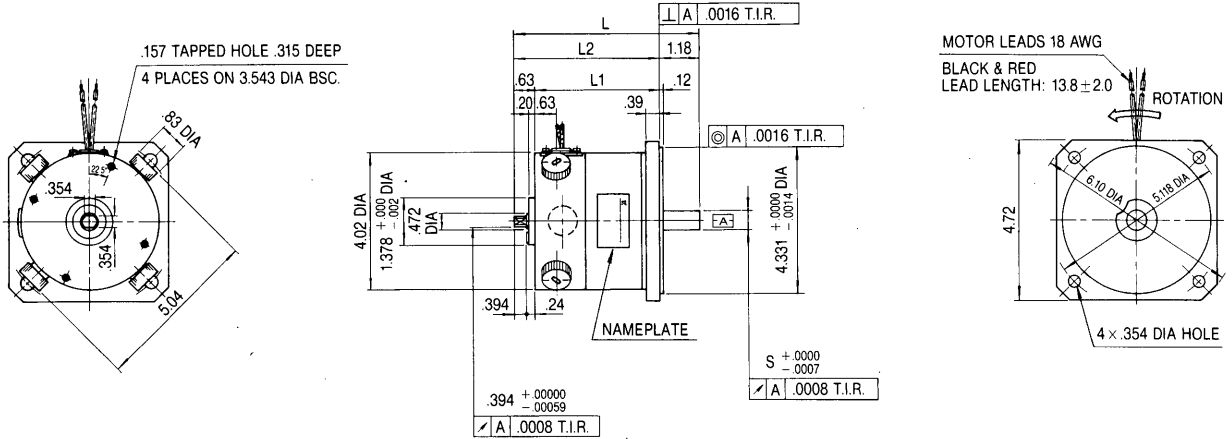

Drawing 4

Type R40

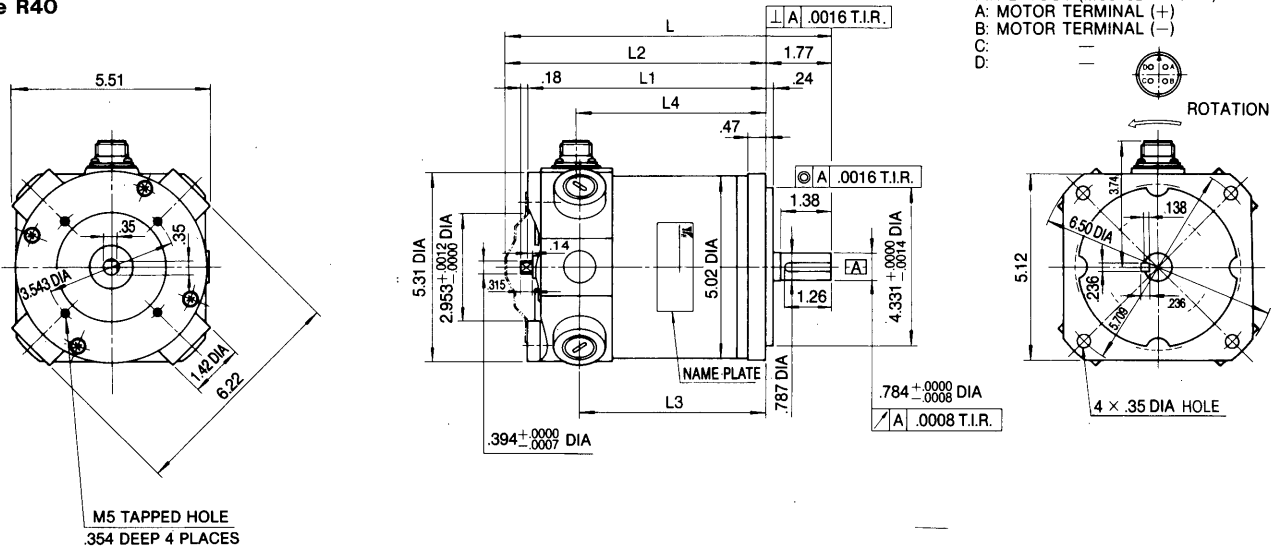

Drawing 5

Motor Type	Dwg	L ₁	L ₂	L ₃	L ₄	L	S	Allowable Load (lb)	
								Thrust	Radial
RO1SAK	1	—	—	—	—	—	—	4.4	8.8
RO2SA2	2	2.99	3.78	—	—	4.96	—	8.8	17.6
RO2MA2		4.09	4.88	—	—	6.06	—		
RO4SA2	3	3.19	6.06	—	—	5.24	—	8.8	33
RO4MA2		4.21	5.08	—	—	6.26	—		
RO8SA2	4	3.70	4.33	—	—	5.51	.551	22	55
RO8MA2		4.65	5.28	—	—	6.46	.629		
R40SA2	5	6.26	6.89	4.80	4.92	8.66	—	22	55
R40MA2		7.64	8.27	6.18	6.30	10.04	—		

Note: CCW rotation with positive voltage applied to red lead and minus voltage, to black lead when viewed from shaft "A" end.

MOTORS WITH DETECTORS

Type RO1

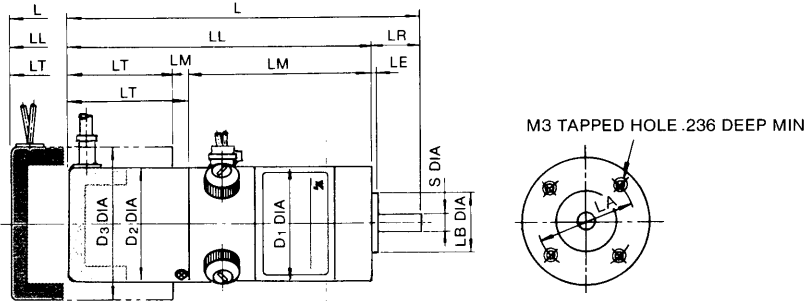

- OP: Optical encoder
- TG: DC tachometer generator
- FBU: Feedback unit (OP + TG)

Motor Type	Detector	D1	D2	D3	LA	LB	LC	LD	LE	LG	LM	LR	L	LL	LT	S	Weight lb
R01SAKOE	OP	1.5	1.5	—	1.260	0.787 _{+0 -0.0008}	—	—	0.06	—	2.56	0.63	4.53	3.90	1.30	0.236 _{+0 -0.0005}	0.89
R01SAK07	TG		—	2.01							2.60		5.31	4.69	2.09		

Type RO2

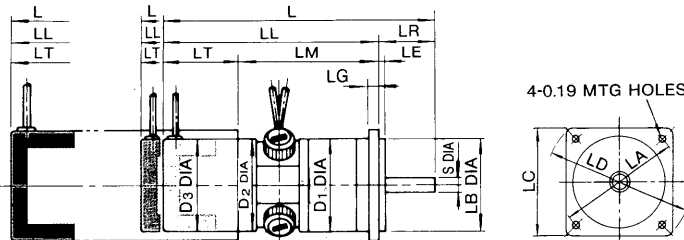

Motor Type	Detector	D1	D2	D3	LA	LB	LC	LD	LE	LG	LM	LR	L	LL	LT	S	Weight lb
R02SA2OE	OP	2.01	2.01	2.01	3.150	1.968 _{+0 -0.0010}	2.56	3.55	0.12	0.24	2.99	1.18	5.43	4.25	1.26	0.315 _{+0 -0.0006}	1.77
R02SA2O7	TG			2.01									6.22	5.04	2.05		2.00
R02SA2OF	FBU			2.36									9.14	7.96	4.96		2.64
R02MA2OE	OP	2.01	2.01	2.01	3.150	1.968 _{+0 -0.0010}	2.56	3.55	0.12	0.24	4.09	1.18	6.53	5.35	1.26	0.315 _{+0 -0.0006}	2.43
R02MA2O7	TG			2.01									7.33	6.14	2.05		2.65
R02MA2OF	FBU			2.36									10.24	9.06	4.96		3.52

Type RO4

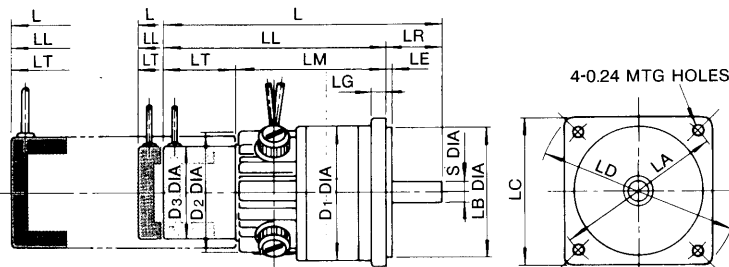

Motor Type	Detector	D1	D2	D3	LA	LB	LC	LD	LE	LG	LM	LR	L	LL	LT	S	Weight lb
R04SA2OE	OP	2.88	2.84	2.01	3.543	2.756 _{+0 -0.0013}	3.15	4.14	0.12	0.31	3.19	1.18	5.63	4.45	1.26	0.433 _{+0 -0.0007}	3.09
R04SA2O7	TG			2.01									6.42	5.24	2.05		3.53
R04SA2OF	FBU			2.36									9.33	8.15	4.96		4.18
R04MA2OE	OP	2.88	2.84	2.01	3.543	2.756 _{+0 -0.0013}	3.15	4.14	0.12	0.31	4.21	1.18	6.65	5.47	1.26	0.433 _{+0 -0.0007}	4.85
R04MA2O7	TG			2.01									7.44	6.26	2.05		5.06
R04MA2OF	FBU			2.36									10.36	9.18	4.96		5.72

Minertia® Motor R Series

Type R01 to R40

Type R08

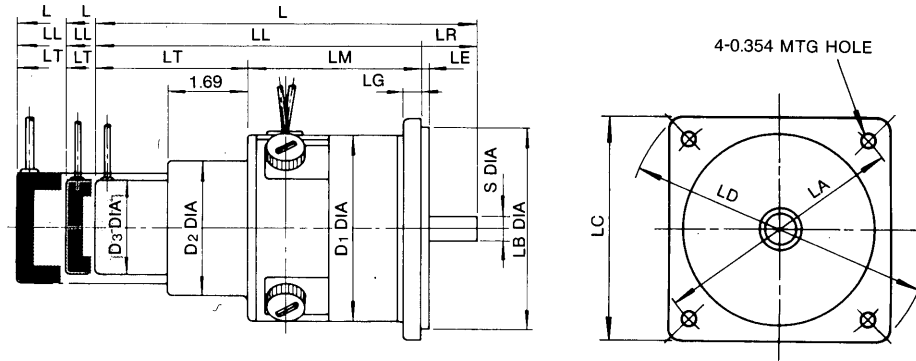

Motor Type	Detector	D1	D2	D3	LA	LB	LG	LD	LE	LG	LM	LR	L	LL	LT	S	Weight lb
R08SA20E	OP	4.02	2.88	2.01	5.118	4.331 +0 -0.0014	4.72	6.10	0.12	0.39	3.90	1.18	8.04	6.85	2.96	0.551 +0 -0.0006	8.36
R08SA207	TG			2.01									8.76	7.58	3.92		8.80
R08SA20F	FBU			2.36									9.79	8.61	4.77		9.24
R08MB20E	OP	4.92	2.88	2.01	5.118	4.331 +0 -0.0014	4.72	6.10	0.12	0.39	4.84	1.18	8.78	7.80	2.96	0.630 +0 -0.0007	11.56
R08MB207	TG			2.01									9.84	8.66	3.82		12.0
R08MB20F	FBU			2.36									10.79	9.61	4.77		12.4

Type R40

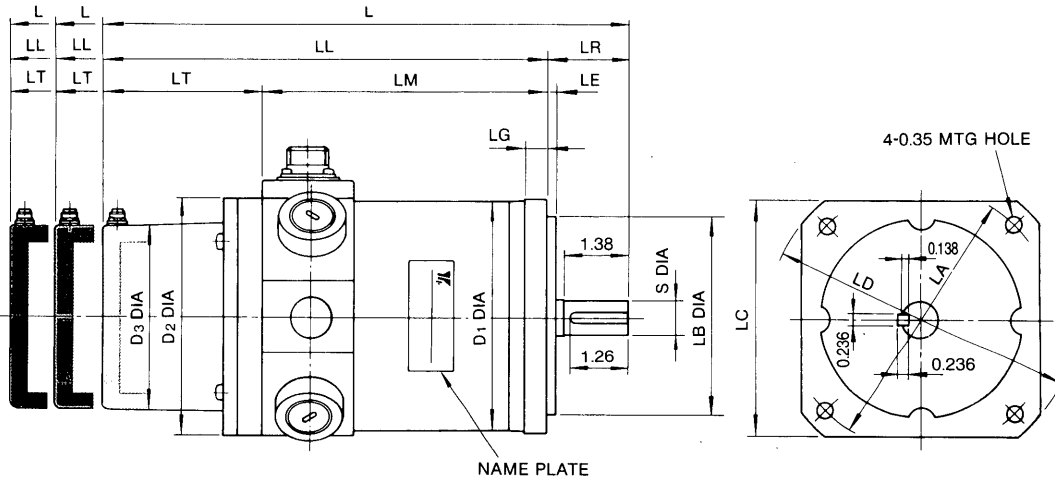

Motor Type	Detector	D1	D2	D3	LA	LB	LC	LD	LE	LG	LM	LR	L	LL	LT	S	Weight lb
R40SA20E	OP	5.02	5.31	3.94	5.709	4.331 +0.0000 -0.0014	5.12	6.50	0.24	0.47	5.91	1.77	11.14	9.37	3.46	0.748 +0.0000 -0.0008	20.28
R40SA207	TG												11.93	10.16	4.25		20.94
R40SA20F	FBU												13.11	11.34	5.43		22.05
R40MA20E	OP	5.02	5.31	3.94	5.709	4.331 +0.0000 -0.0014	5.12	6.50	0.24	0.47	7.29	1.77	12.52	10.75	3.46	0.748 +0.0000 -0.0008	26.46
R40MA207	TG												13.31	11.54	4.25		27.17
R40MA20F	FBU												14.49	12.92	5.43		28.22

MINERTIA MOTOR R SERIES BULLETIN

TOKYO OFFICE Ohtemachi Bldg, 1-6-1 Ohtemachi, Chiyoda-ku, Tokyo, 100 Japan
Phone (03) 3284-9111 Telex YASKAWA J33530 Fax (03) 3284-9034

YASKAWA ELECTRIC AMERICA, INC.

Chicago-Corporate Headquarters 2942 MacArthur Blvd. Northbrook, IL 60062-2028, U.S.A.

Phone (708) 291-2340 Fax (708) 498-2430

Chicago-Technical Center 3160 MacArthur Blvd. Northbrook, IL 60062-1917, U.S.A.

Phone (708) 291-0411 Fax (708) 291-1018

MOTOMAN INC.

805 Liberty Lane West Carrollton, OH 45449, U.S.A.

Phone (513) 847-6200 Fax (513) 847-6277

YASKAWA ELÉTRICO DO BRASIL COMÉRCIO LTDA.

Rua Conde Do Pinhal 8-5°, Andar Sala 51 CEP 01501-São Paulo-SP, Brasil

Phone (011) 35-1911 Fax (011) 37-7375

YASKAWA ELECTRIC EUROPE GmbH

Am Kronberger Hang 2, 65824 Schwalbach, Germany

Phone (49) 6196-569-300 Fax (49) 6196-888-301

Motoman Robotics AB

Box 130 S-38500, Torsås, Sweden

Phone 0486-10575 Fax 0486-11410

Motoman Robotec GmbH

Kammerfeldstraße 1, 85391 Allershausen, Germany

Phone 08166-900 Fax 08166-9039

YASKAWA ELECTRIC UK LTD.

3 Drum Mains Park Orchardton Woods Cumbernauld, Scotland, G68 9LD U.K.

Phone (236)735000 Fax (236)458182

YASKAWA ELECTRIC KOREA CORPORATION

8th Floor Seoul Center Bldg, 91-1, Sogong-Dong, Chung-ku, Seoul, Korea 100-070

Phone (02)776-7844 Fax (02)753-2639

YASKAWA ELECTRIC (SINGAPORE) PTE. LTD.

Head Office : CPF Bldg, 79 Robinson Road # 13-05, Singapore 0106, SINGAPORE

Phone 221-7530 Telex (87) 24890 YASKAWA RS Fax 224-5854

Service Center : 221 Henderson Road, # 07-20 Henderson Building Singapore 0315, SINGAPORE

Phone 276-7407 Fax 276-7406

YATEC ENGINEERING CORPORATION

Shen Hsiang Tang Sung Chiang Building 10F 146 Sung Chiang Road, Taipei, Taiwan

Phone (02) 563-0010 Fax (02) 567-4677

SHANGHAI OFFICE Room No. 8B Wan Zhong Building 1303 Yan An Road (West), Shanghai 200050, CHINA

Phone (86) 212-1015 Fax (86) 212-1015

TAIPEI OFFICE Shen Hsiang Tang Sung Chiang Building 10F 146 Sung Chiang Road, Taipei, Taiwan

Phone (02) 563-0010 Fax (02) 567-4677



YASKAWA ELECTRIC CORPORATION

YASKAWA

TSE-C253-20H

© Printed in Japan February 1995 84-10 0.5WA 

Due to ongoing product modification/improvement, data subject to change without notice.

584-42