

* - INDICATES COMPONENTS NOT SUPPLIED BY YASKAWA.
 --- INDICATES CUSTOMER WIRING.
 SEE DRAWING UDE00391 FOR CUSTOMER CONNECTION TABLES.
 SEE DRAWING UDE00392 FOR DRIVE PARAMETER SETTINGS.

- NOTES:
- CONNECTED TO THE CABINET. CUSTOMER TO CONNECT THE CABINET GROUND LUGS TO EARTH GROUND AND UTILITY GROUND.
 - CONDUIT FITTINGS/HUBS SHALL COMPLY WITH THE 'STANDARD FOR CONDUIT, TUBING, AND CABLE FITTINGS, UL 514B'. OR CONDUIT FITTINGS HAVING THE SAME ENVIRONMENTAL RATING AS THE ENCLOSURE SHALL BE USED.
 - WITHOUT THE CIRCUIT BREAKER (OPTION PC OR PE), OR DISCONNECT SWITCH OPTION PD, THE DISCONNECT MEANS MUST BE SUPPLIED BY THE CUSTOMER.
 - BRANCH CIRCUIT PROTECTION TO BE SUPPLIED BY THE CUSTOMER WHEN NOTED ON THE CABINET DATA NAMEPLATE.
 - INSULATED TWISTED SHIELDED WIRE IS REQUIRED. SHIELD TO CONNECT TO PROPER TERMINALS AS SHOWN. CONNECT THE SHIELD ONLY AT THIS END. STUB AND ISOLATE THE OTHER END. DO NOT RUN THESE WIRES IN THE SAME CONDUIT AS THE AC POWER AND AC CONTROL WIRES. KEEP ALL WIRING UNDER 50m IN LENGTH.
 - CUSTOMER TO ADJUST THE THERMOSTAT ON THE SPACE HEATER HR1 FOR THE MINIMUM DESIRED TEMPERATURE INSIDE THE DRIVE CABINET. THIS SET TEMPERATURE IS NORMALLY SELECTED TO BE SLIGHTLY HIGHER THAN THE MINIMUM AMBIENT TEMPERATURE OF THE AIR SURROUNDING THE CABINET, AND IS THE TEMPERATURE AT WHICH THE SPACE HEATER HR1 WILL SHUT OFF.
 - FOR A CONTROL TRANSFORMER T1 POWER RATING OF 350VA OR GREATER, SECONDARY FUSE F6 IS ADDED.
 - IF AC MOTOR IS FURNISHED WITH A N.C. THERMAL SWITCH THEN SET DRIVE PARAMETER H1-08 TO 27. THIS WILL CAUSE THE DRIVE TO COAST TO STOP UPON AN AC MOTOR THERMAL FAULT. ALONG WITH THIS, ADD THE FOLLOWING CUSTOMER WIRING: WIRE THE N.C. THERMAL SWITCH BETWEEN TERMINAL S8 OF THE 120VAC INTERFACE CARD AND ONE SIDE OF THE 120VAC SOURCE.
 - OPTIONS TD, TG, TH, TJ, TL, TQ OR TU CONTROL (SEE UDE00392 FOR MORE INFORMATION)
 - CUSTOMER TO REPLACE THE JUMPER WITH NORMALLY CLOSED SAFETY INTERLOCKS, IF APPLICABLE.

REVISIONS				DRAWN BY		DATE		TITLE	
REV.	DESCRIPTION	ECO #	DRAWN BY	DATE	D.R. CMELAK	11/16/12	SCHEMATIC DIAGRAM IQPUMP1000 CONFIGURED TYPE 3R - F2 ENCL		
10	UPDATE WIRE LABELS ON Q1C3 WITH VMR	14055	JZ	08/29/24	D. PACKER	11/16/12	SIZE	REVISION	PAGE
09	ADD S3 AND S4 TERMINAL LABELS	10630	KG	06/09/20	APPROVED: K. FLIERL 11/16/12		D	10	1 of 3
08	ADD OPTION P9 SURGE SUPPRESSOR	8264	RCR	01/08/18	ORIGINAL DESIGN: D.R. CMELAK 11/16/12		DRAWING# DS.Q1C3R.03		

YASKAWA

THIS DOCUMENT AND INFORMATION CONTAINED IN IT ARE CONFIDENTIAL, AND CANNOT BE COPIED OR DISCLOSED IN WHOLE OR IN PART WITHOUT THE EXPRESS WRITTEN CONSENT OF YASKAWA AMERICA INC.

201
202
203
204
205
206
207
208
209
210
211
212
213
214
215
216
217
218
219
220
221
222
223
224
225
226
227
228
229
230
231
232
233
234
235
236
237
238
239
240
241

CONTROL TRANSFORMER PRIMARY CONNECTIONS			
INPUT VOLTS	TERMINALS		JUMPER LOCATION
	A	B	
208	(H1)	(H2)	NONE
230/240	(H1)	(H4)	(H1) TO (H3) (H2) TO (H4)
460/480	(H1)	(H4)	(H2) TO (H3)
600	(H1)	(H2)	NONE

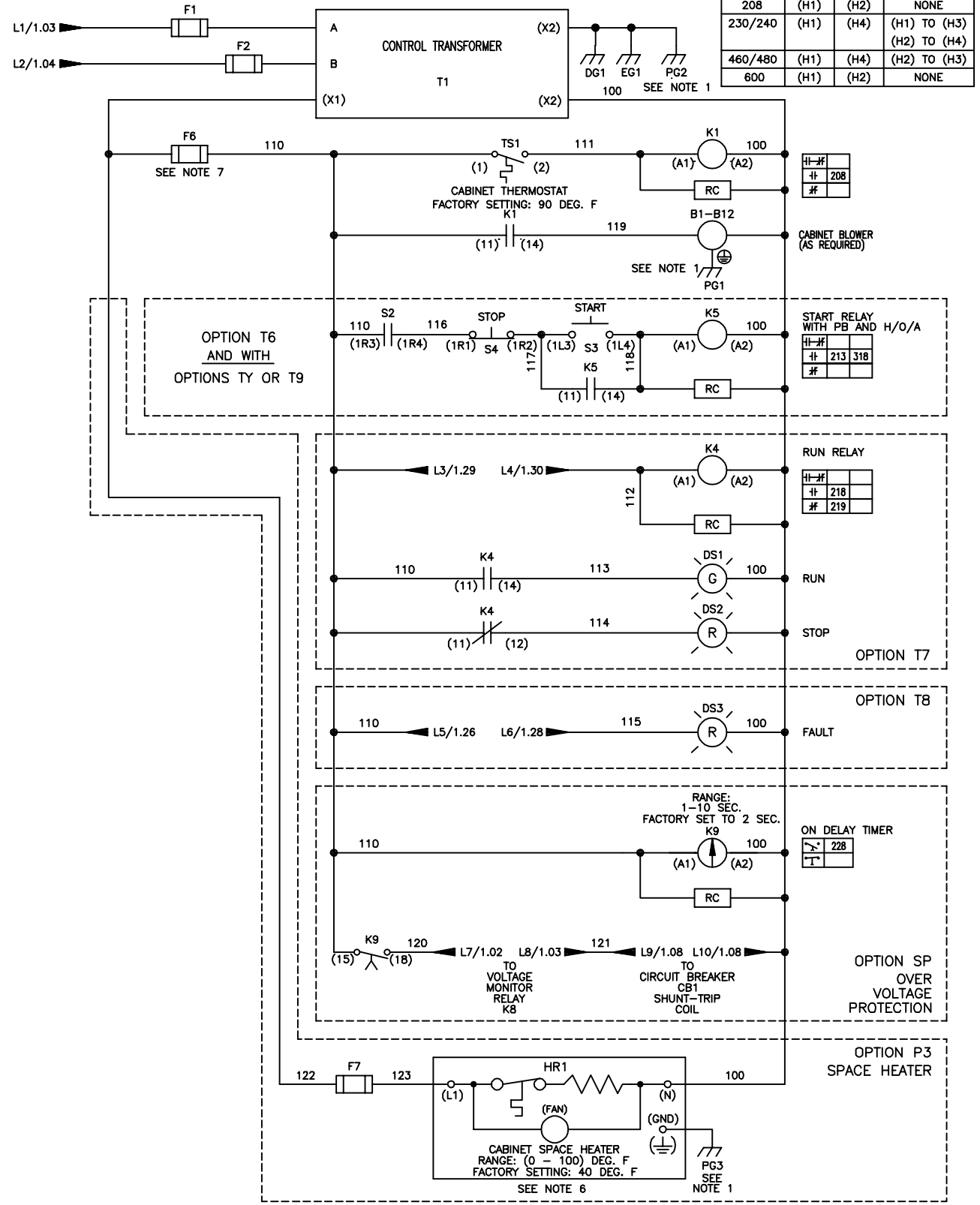

YASKAWA	DRAWN BY: D.R. CMELAK	DATE: 11/16/12	TITLE: SCHEMATIC DIAGRAM
	CHECKED: D. PACKER	DATE: 11/16/12	IQPUMP1000 CONFIGURED
	TECH: _____	DATE: _____	TYPE 3R - F2 ENCL
	APPROVED: K. FLIERL	DATE: 11/16/12	SIZE: D
ORIGINAL DESIGN: D.R. CMELAK	DATE: 11/16/12	REVISION: 10	PAGE: 2 of 3
THIS DOCUMENT AND INFORMATION CONTAINED HEREIN ARE CONFIDENTIAL, AND CANNOT BE COPIED OR DISCLOSED IN WHOLE OR IN PART WITHOUT THE EXPRESS WRITTEN CONSENT OF YASKAWA AMERICA INC.			DRAWING#: DS.Q1C3R.03

RUN/STOP CONTROL (FROM SHEET 1)

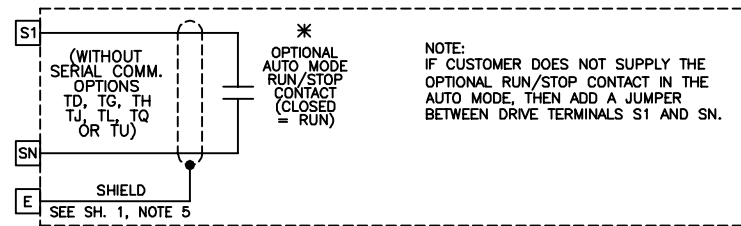

OR

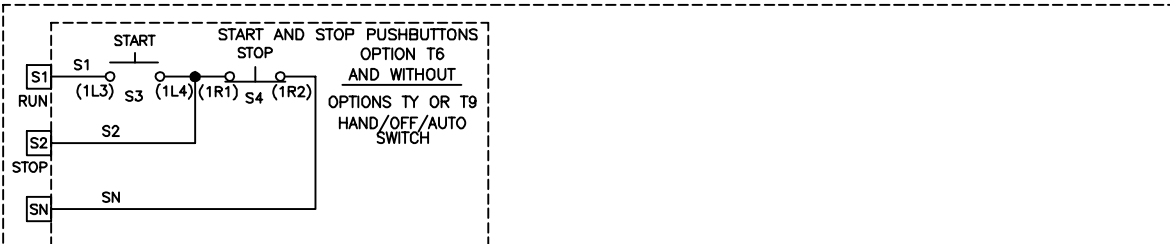

OR

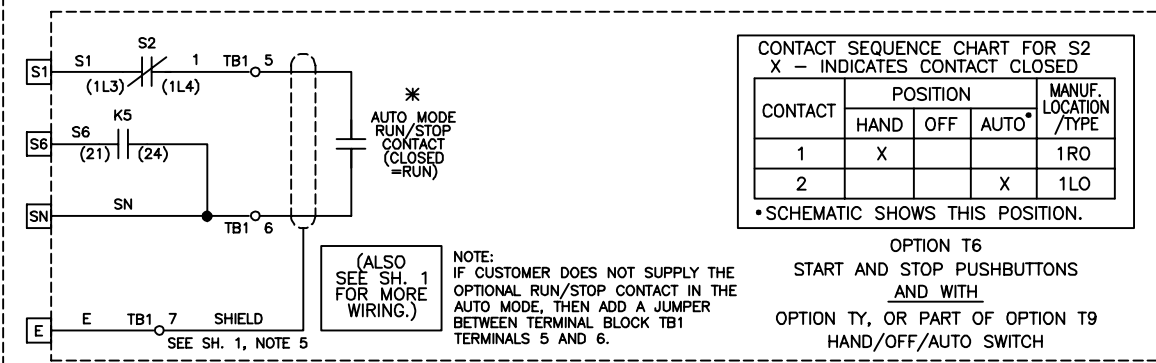

OR

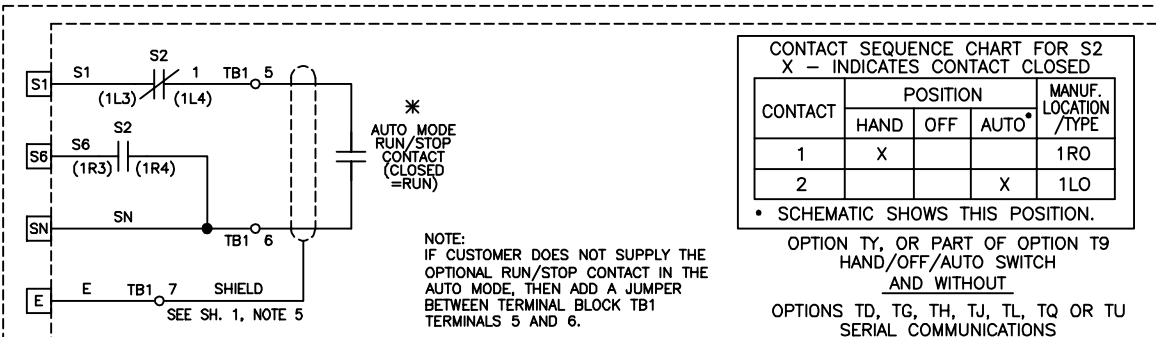

OR

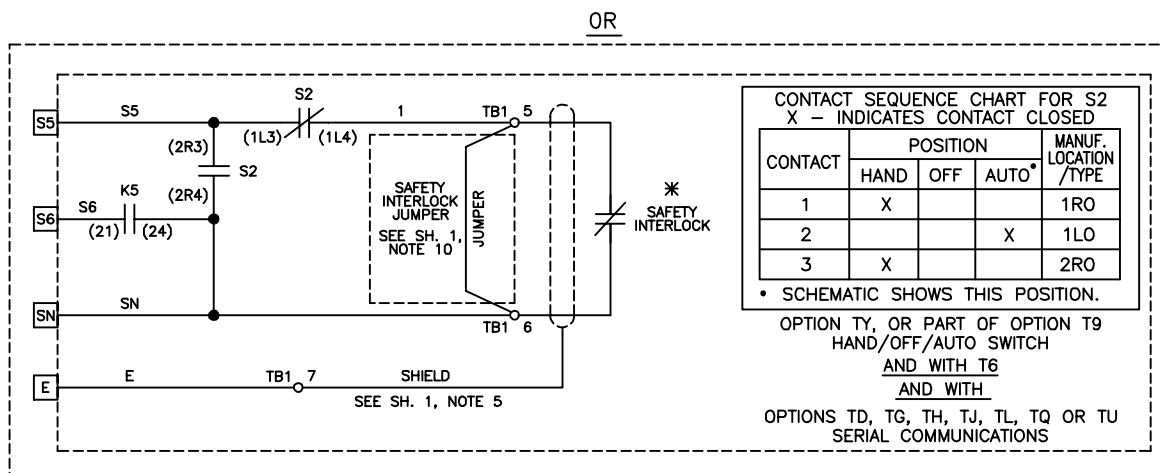
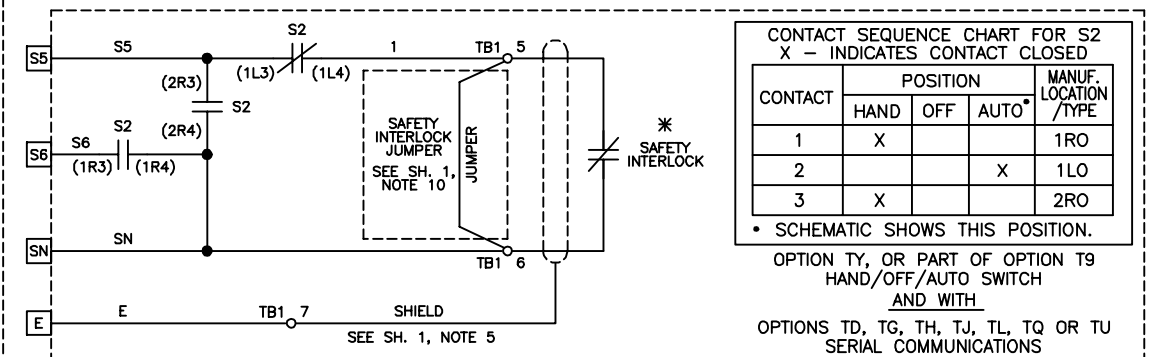

YASKAWA

THIS DOCUMENT AND INFORMATION CONTAINED IN IT ARE CONFIDENTIAL, AND CANNOT BE COPIED OR DISCLOSED IN WHOLE OR IN PART WITHOUT THE EXPRESS WRITTEN CONSENT OF YASKAWA AMERICA INC.

DRAWN BY:	D.R. CMELAK	DATE:	11/16/12
CHECKED:	D. PACKER	DATE:	11/16/12
APPROVED:	K. FLIERL	DATE:	11/16/12
ORIGINAL DESIGN:	D.R. CMELAK	DATE:	11/16/12

TITLE:	SCHEMATIC DIAGRAM IQPUMP1000 CONFIGURED TYPE 3R - F2 ENCL		
SIZE:	D	REVISION:	10
PAGE:	3 of 3		
DRAWING#:	DS.Q1C3R.03		