

MODEL #	INPUT VOLTAGE (kV)	VOLTAGE CLASS (kV) (MOTOR)	DRIVE CURRENT RATING (A)	RATED POWER (HP)	HEAT DISSIPATION (kW)	TOTAL WEIGHT (lbs)[Kg]*	WIDTH (Inches [mm])	DEPTH (Inches [mm])	HEIGHT (Inches [mm])
MV2UA6AA140E3ABB	2.4	2.4	140	600	13.0	EST. 11000 [4990]	140.4 [3565]	89.0 [2260]	99.1 [2517]
MV2UD6DA070E3ABB	4.16	4.16	70	500	11.2				
MV2UD6DA140E3ABB			140	1000	22.4				

* DOES NOT INCLUDE SHIPPING CONTAINER

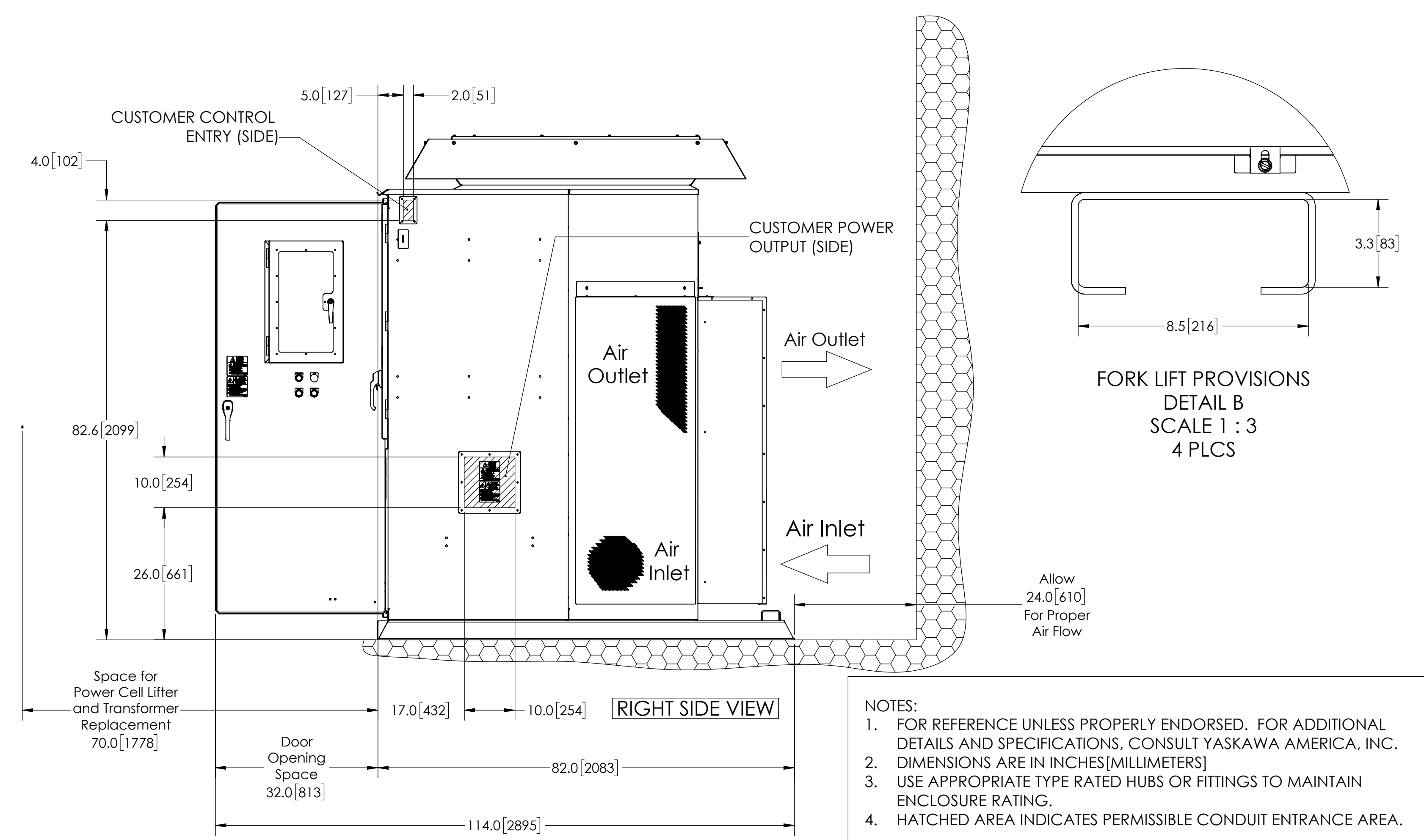
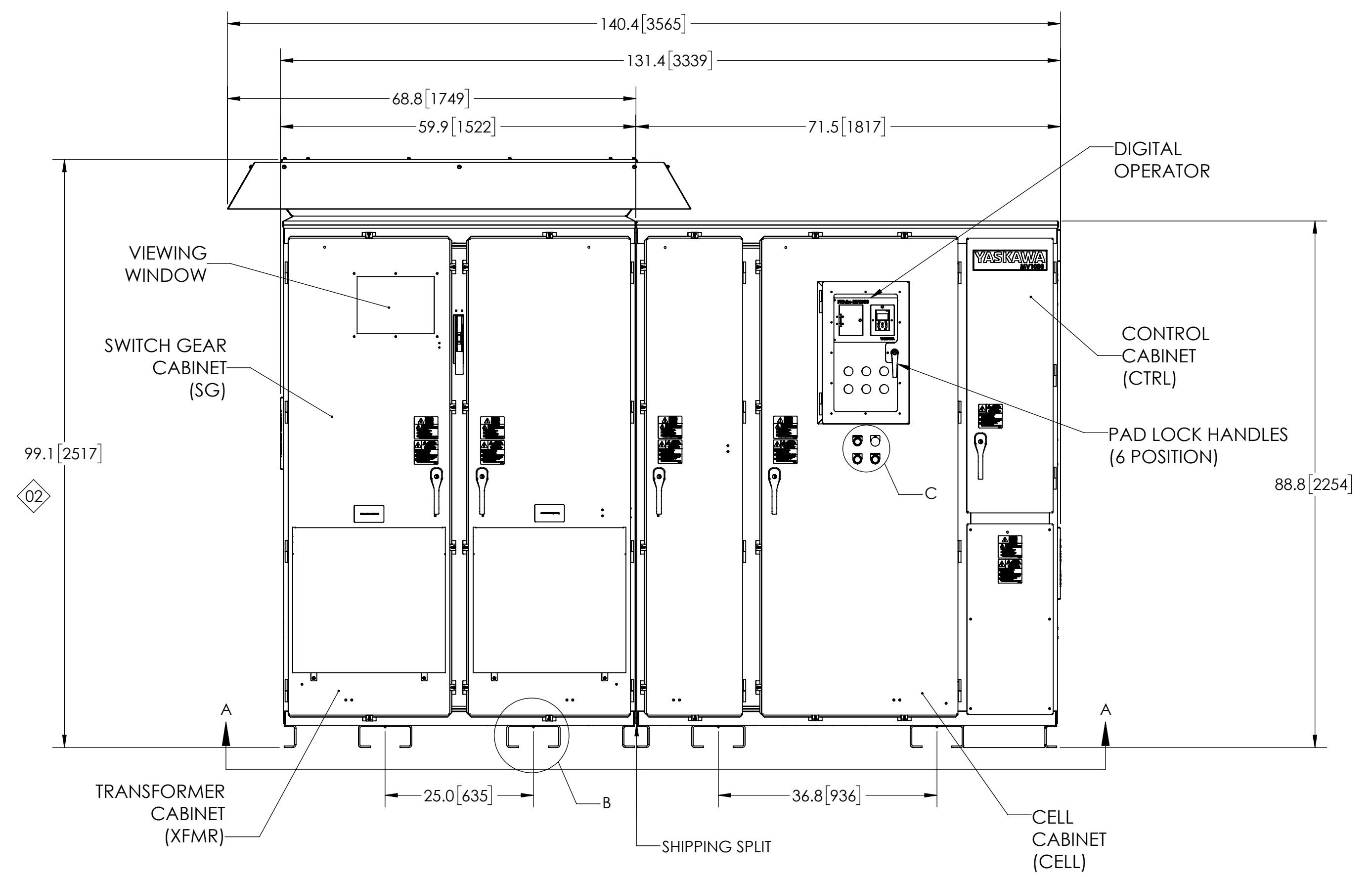
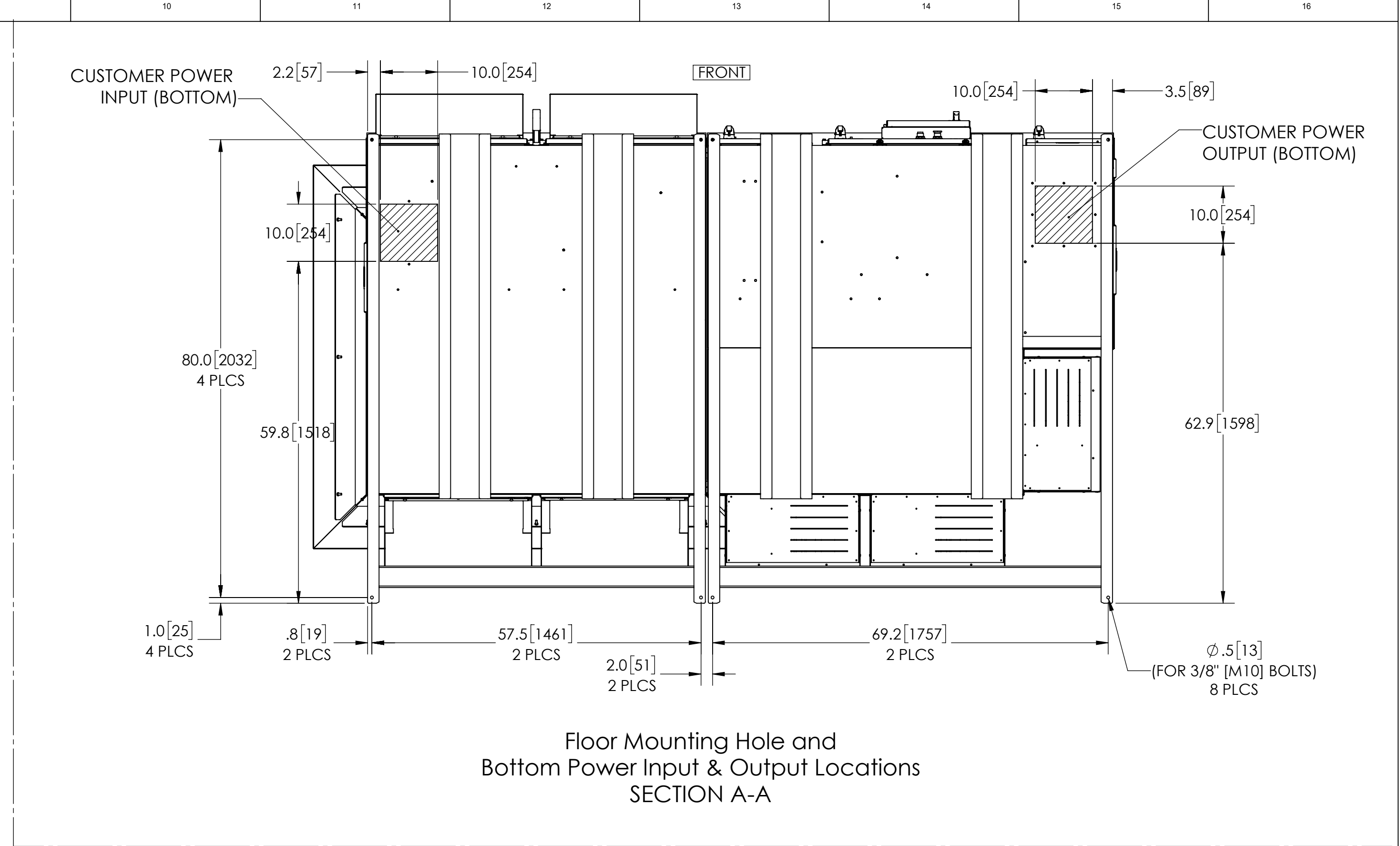
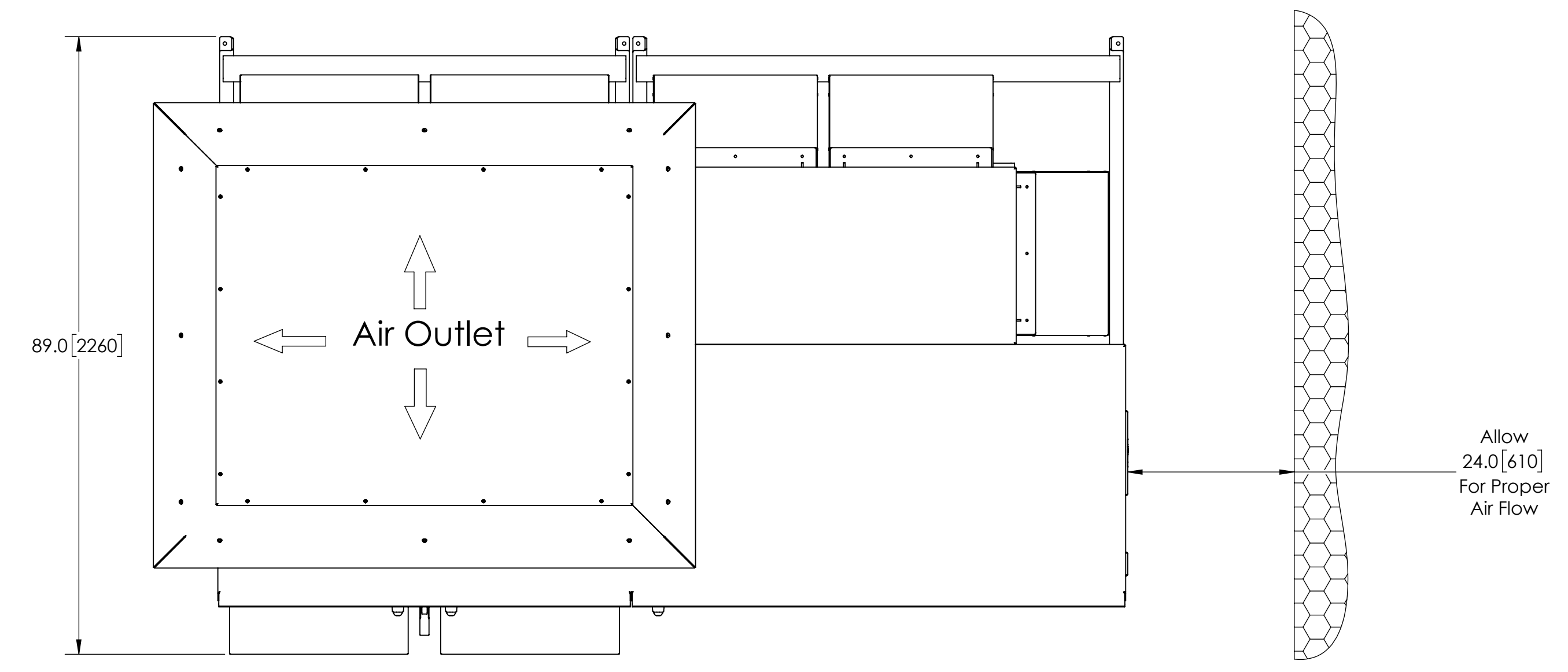

- NOTES:
- FOR REFERENCE UNLESS PROPERLY ENDORSED. FOR ADDITIONAL DETAILS AND SPECIFICATIONS, CONSULT YASKAWA AMERICA, INC.
 - DIMENSIONS ARE IN INCHES[MILLIMETERS]
 - USE APPROPRIATE TYPE RATED HUBS OR FITTINGS TO MAINTAIN ENCLOSURE RATING.
 - HATCHED AREA INDICATES PERMISSIBLE CONDUIT ENTRANCE AREA.

REV.	DESCRIPTION	ECR#	DRAWN BY	DATE
02	CHANGED HEIGHT TO 99.1 FROM 98.6	8223	EKR	10/23/2017
01	ADDED PAGE 3 TO ILLUSTRATE J-BOX OPTION	8180	BJS	9/28/2017
00	INITIAL RELEASE	-	CJM	5/26/2017

elliott_rashed Wednesday, October 25, 2017 3:16:35 PM

ENCLOSURE	UL TYPE 3R (XFMR)/IP55 (CELL)	
COLOR	OUTSIDE	WHITE LEATHER, HENTZEN P40147WPC
	INSIDE	WHITE LEATHER, HENTZEN P40147WPC

ITEM NO.	NAME
(XFMR)	TRANSFORMER CABINET
(CELL)	CELL CABINET
(CTRL)	CONTROL CABINET
(SG)	SWITCH GEAR CABINET

YASKAWA

THIS DOCUMENT AND INFORMATION CONTAINED IN IT ARE CONFIDENTIAL, AND CANNOT BE COPIED OR DISCLOSED IN WHOLE OR IN PART WITHOUT THE EXPRESS WRITTEN CONSENT OF YASKAWA AMERICA INC.

DRAWN: C. Michalek	DATE: 5/26/2017	TITLE: DIMENSIONAL DRAWING, MV1000, FRM 50, TYPE 3R
CHECKED: B. Schowanson	DATE: 5/26/2017	MATERIAL# SEE TABLE
TECH: -	DATE: -	SIZE D
APPROVED: B. Schowanson	DATE: 5/26/2017	REVISION 02
ORIGINAL DESIGN: M. Kanter	DATE: 2/19/2017	PAGE 1 OF 3

DRAWING #: **DD.MV1K.FR50.N3.SG.01**

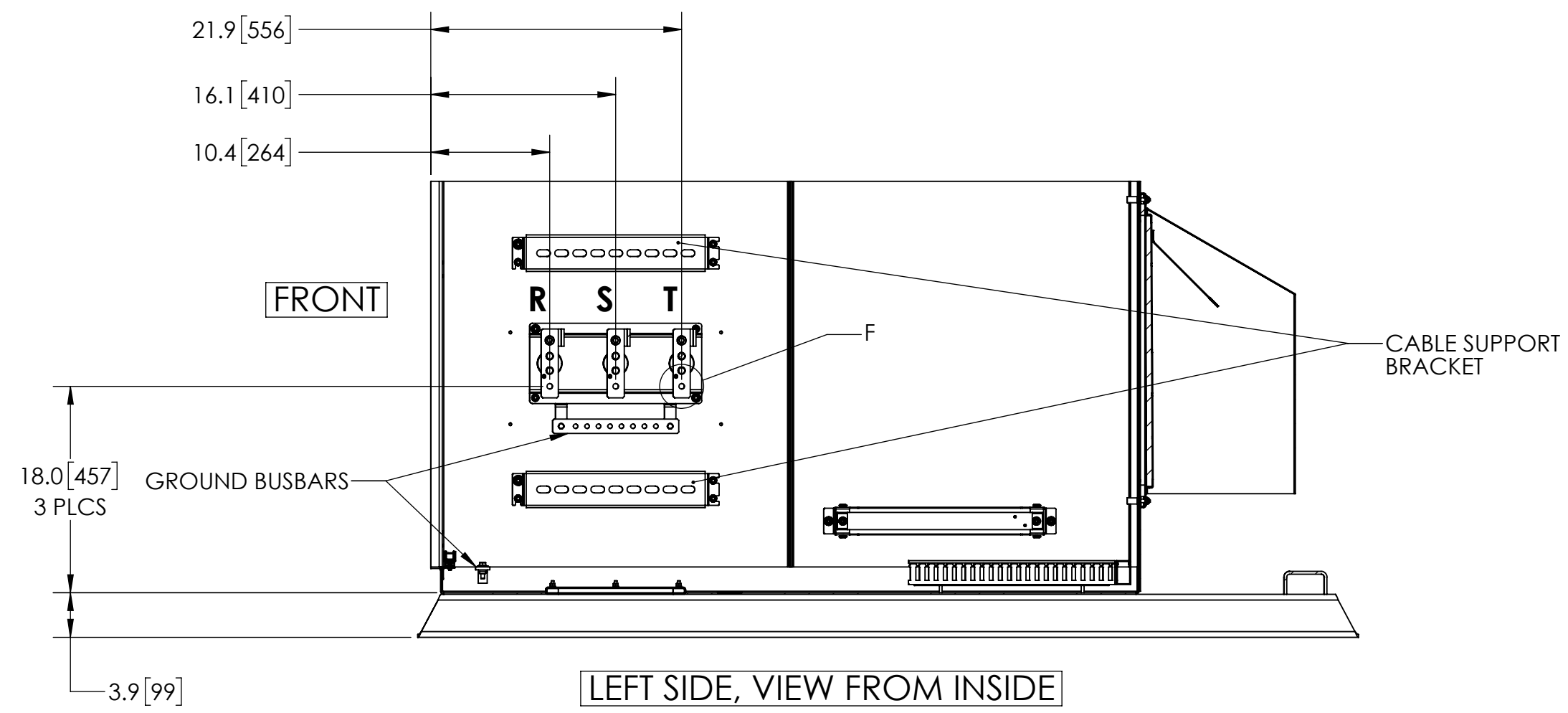
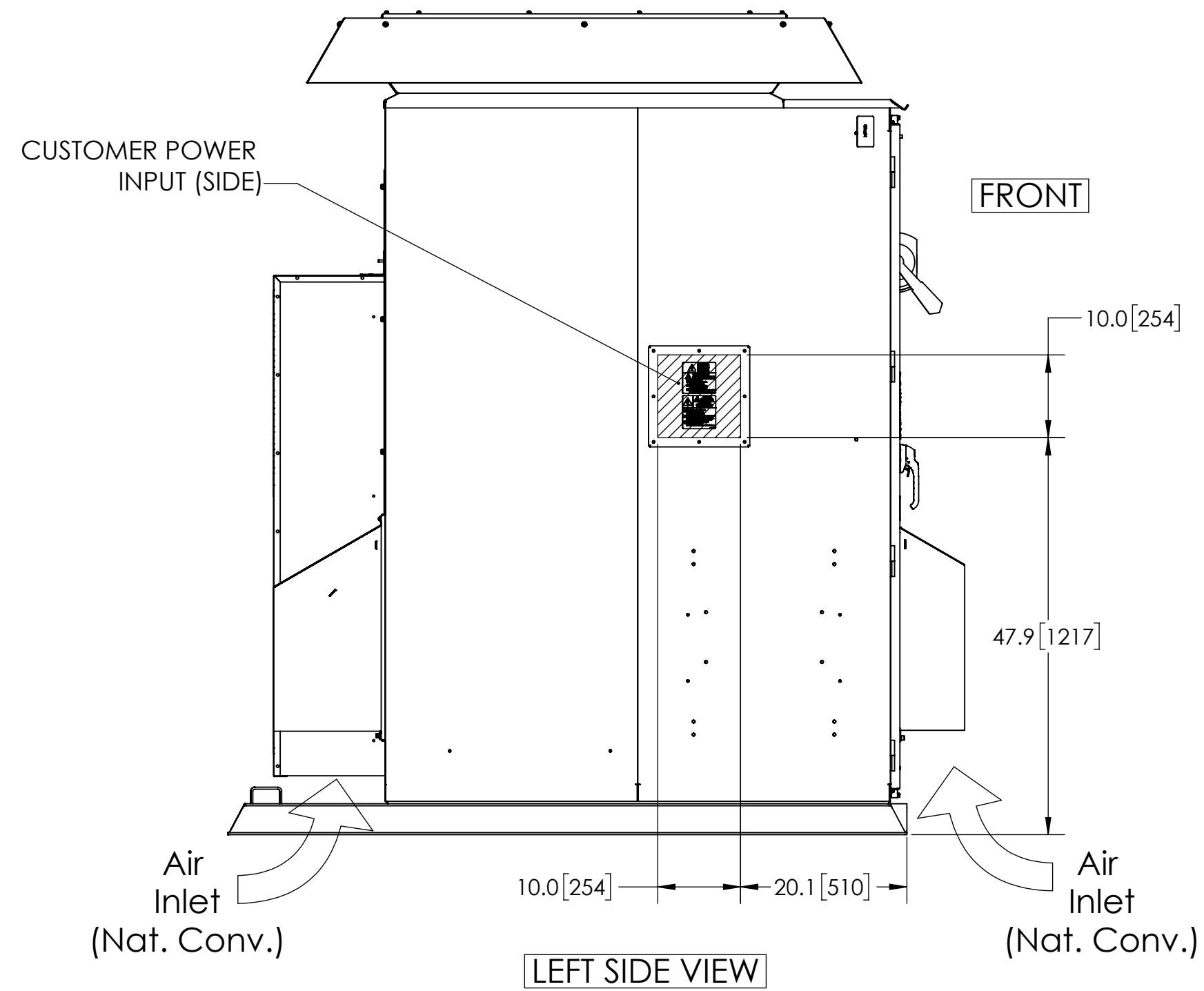

INPUT TERMINAL LOCATIONS SECTION D-D

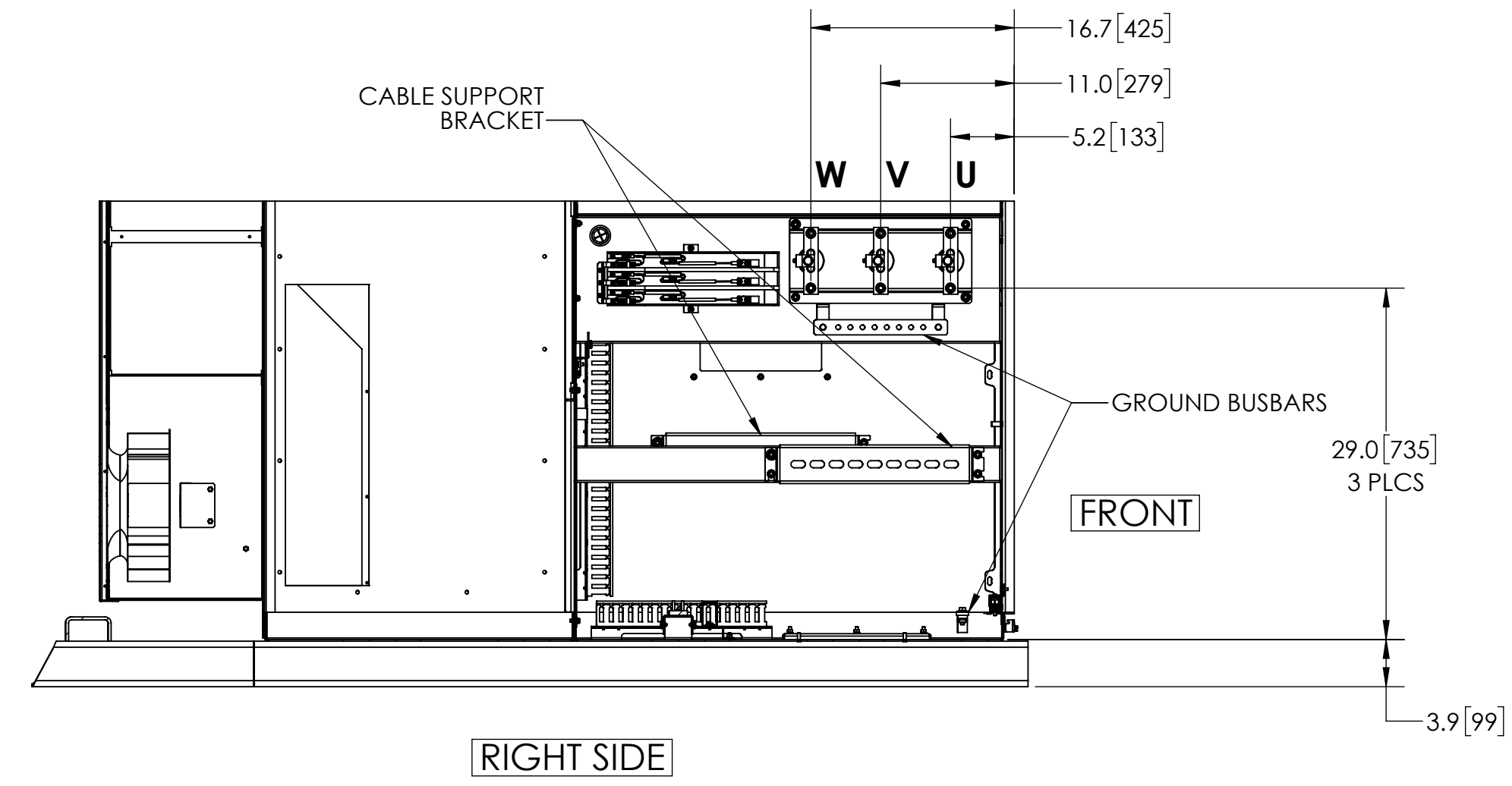
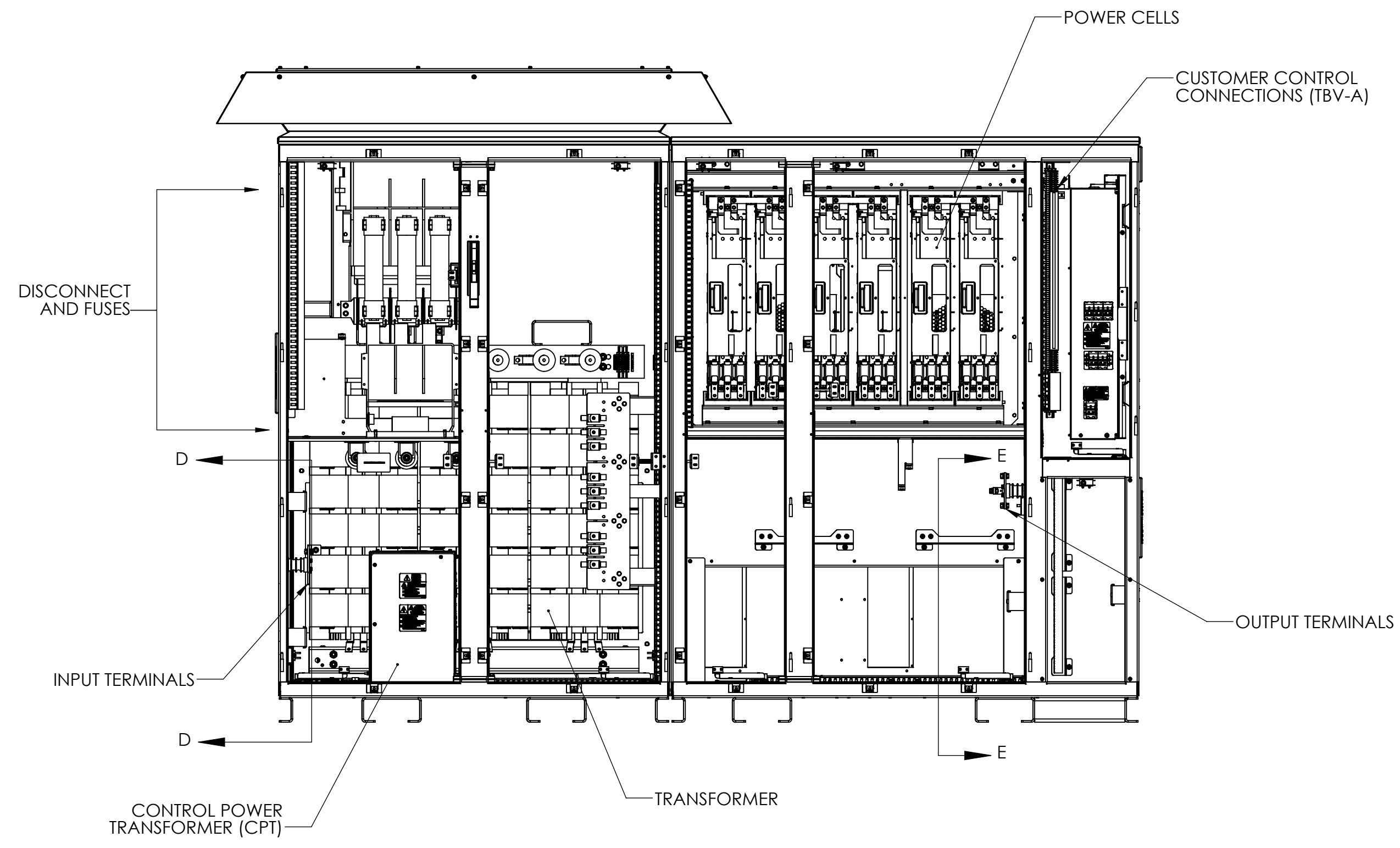
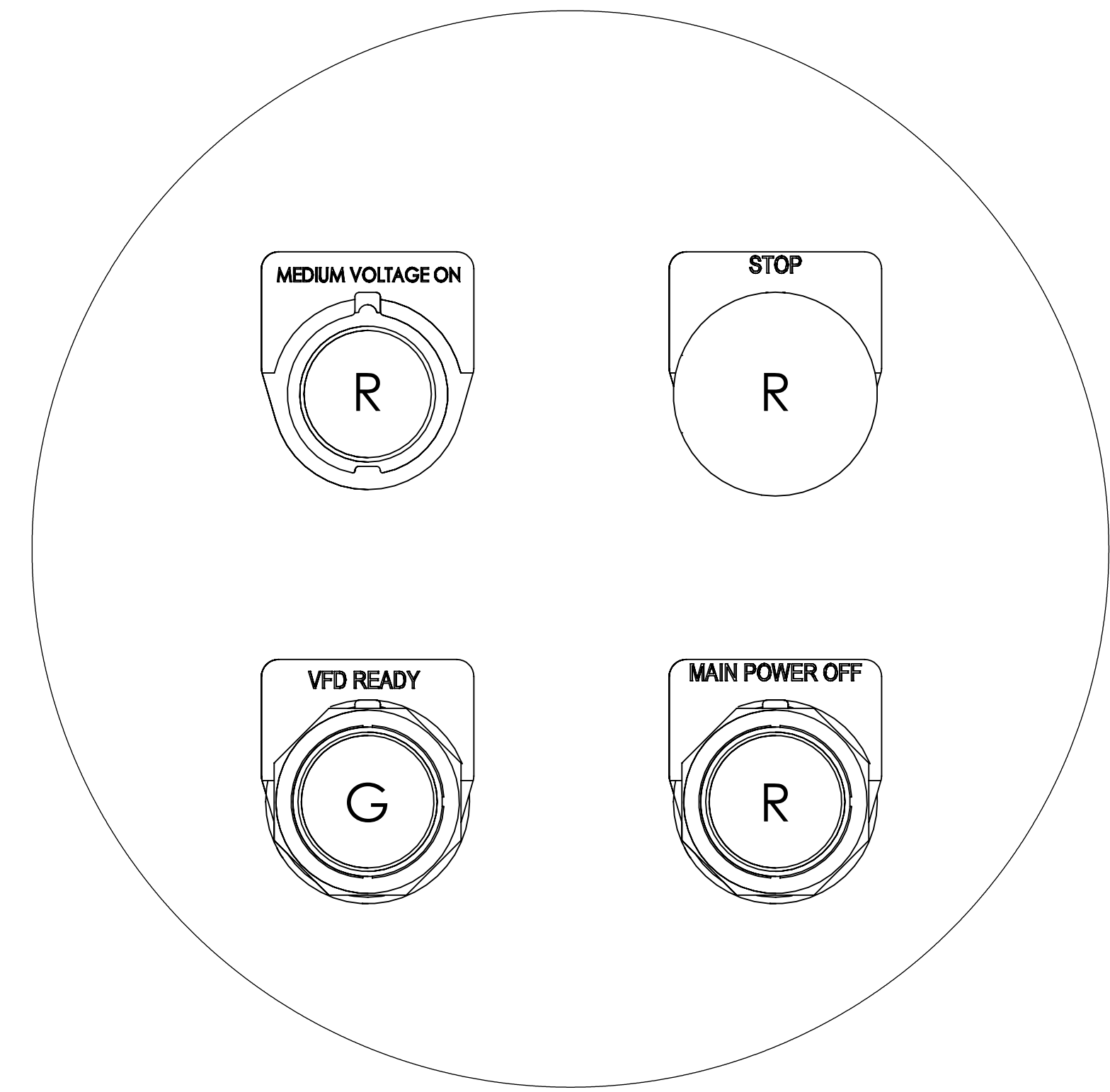

OUTPUT TERMINAL LOCATIONS SECTION E-E

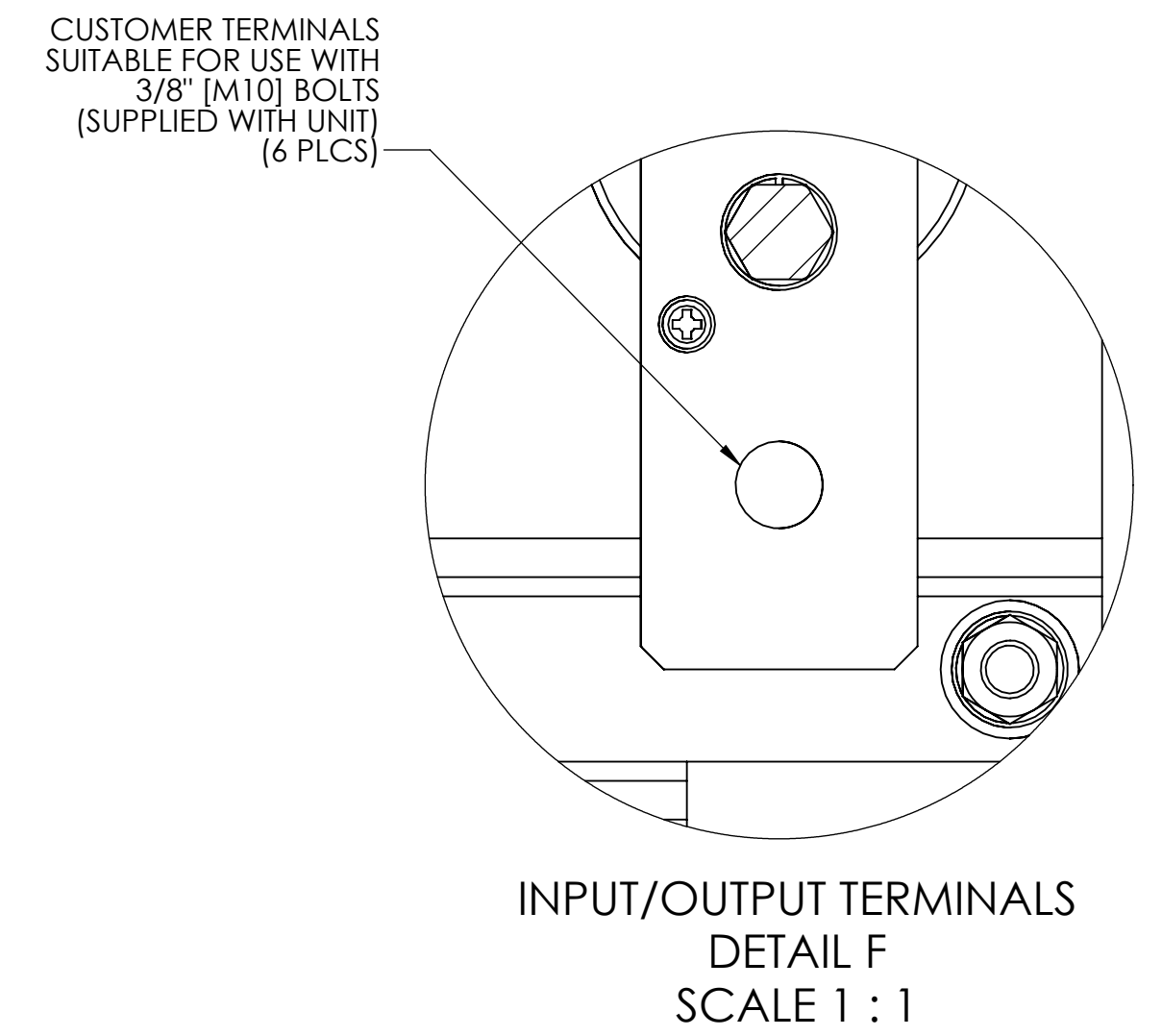

- NOTES:
- FOR REFERENCE UNLESS PROPERLY ENDORSED. FOR ADDITIONAL DETAILS AND SPECIFICATIONS, CONSULT YASKAWA AMERICA, INC.
 - DIMENSIONS ARE IN INCHES[MILLIMETERS]
 - USE APPROPRIATE TYPE RATED HUBS OR FITTINGS TO MAINTAIN ENCLOSURE RATING.
 - HATCHED AREA INDICATES PERMISSIBLE CONDUIT ENTRANCE AREA.

YASKAWA	DRAWN: C. Michalek	DATE 5/26/2017	TITLE: DIMENSIONAL DRAWING, MV1000, FRM 50, TYPE 3R
	CHECKED: B. Schowanson	DATE 5/26/2017	MATERIAL# SEE TABLE
APPROVED: B. Schowanson		DATE 5/26/2017	SIZE D
ORIGINAL DESIGN: M. Kanter		DATE 2/19/2017	REVISION 02
THIS DOCUMENT AND INFORMATION CONTAINED IN IT ARE CONFIDENTIAL, AND CANNOT BE COPIED OR DISCLOSED IN WHOLE OR IN PART WITHOUT THE EXPRESS WRITTEN CONSENT OF YASKAWA AMERICA INC.		DRAWING #: DD.MV1K.FR50.N3.SG.01	PAGE 2 OF 3

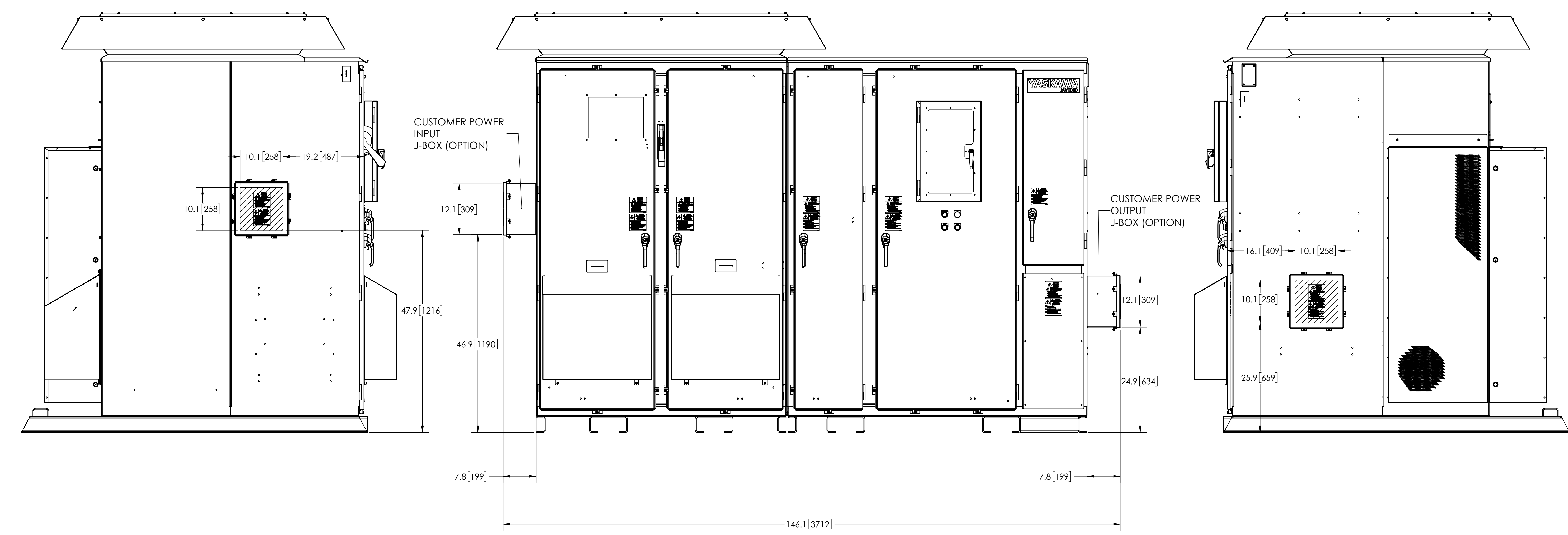

- NOTES:
1. FOR REFERENCE UNLESS PROPERLY ENDORSED. FOR ADDITIONAL DETAILS AND SPECIFICATIONS, CONSULT YASKAWA AMERICA, INC.
 2. DIMENSIONS ARE IN INCHES[MILLIMETERS]
 3. USE APPROPRIATE TYPE RATED HUBS OR FITTINGS TO MAINTAIN ENCLOSURE RATING.
 4. HATCHED AREA INDICATES PERMISSIBLE CONDUIT ENTRANCE AREA.

YASKAWA	DRAWN:	C. Michalek	DATE:	5/26/2017	TITLE:	DIMENSIONAL DRAWING, MV1000, FRM 50, TYPE 3R		
	CHECKED:	B. Schowanson	DATE:	5/26/2017	MATERIAL#	SEE TABLE		
	TECH:	-	DATE:	-	SIZE	D	REVISION	02
	APPROVED:	B. Schowanson	DATE:	5/26/2017	DATE	2/19/2017	PAGE	3 OF 3
THIS DOCUMENT AND INFORMATION CONTAINED IN IT ARE CONFIDENTIAL, AND CANNOT BE COPIED OR DISCLOSED IN WHOLE OR IN PART WITHOUT THE EXPRESS WRITTEN CONSENT OF YASKAWA AMERICA INC.				ORIGINAL DESIGN:	M. Kanter	DRAWING #:		
						DD.MV1K.FR50.N3.SG.01		