

MODEL #	INPUT VOLTAGE (KV)	VOLTAGE CLASS (KV) (MOTOR)	DRIVE CURRENT RATING (A)	RATED POWER (HP)	HEAT DISSIPATION (kW)	TOTAL WEIGHT (lbs)[Kg]*	WIDTH (Inches [mm])	DEPTH (Inches [mm])	HEIGHT (Inches [mm])
MV2UA6AA052E1ABA	2.4	2.4	52	200	4.5	EST. 5840 [2649]	66.4 [1685]	41.5 [1055]	109.3 [2776]
MV2UA6AA068E1ABA			68	300	6.7				
MV2UA6AA080E1ABA			80	350	7.8				
MV2UA6AA093E1ABA			93	400	8.9				
MV2UA6AA102E1ABA			102	450	10.1				
MV2UD6DA039E1ABA	4.16	4.16	39	300	6.7	EST. 5840 [2649]	66.4 [1685]	41.5 [1055]	109.3 [2776]
MV2UD6DA052E1ABA			52	400	8.9				
MV2UD6DA058E1ABA			58	450	10.1				
MV2UD6DA064E1ABA			64	500	11.2				
MV2UD6DA077E1ABA			77	600	13.4				
MV2UD6DA093E1ABA	93	700	15.7	EST. 6800 [3084]	66.4 [1685]	41.5 [1055]	109.3 [2776]		
MV2UD6DA102E1ABA	102	800	17.9						

\* DOES NOT INCLUDE SHIPPING CONTAINER

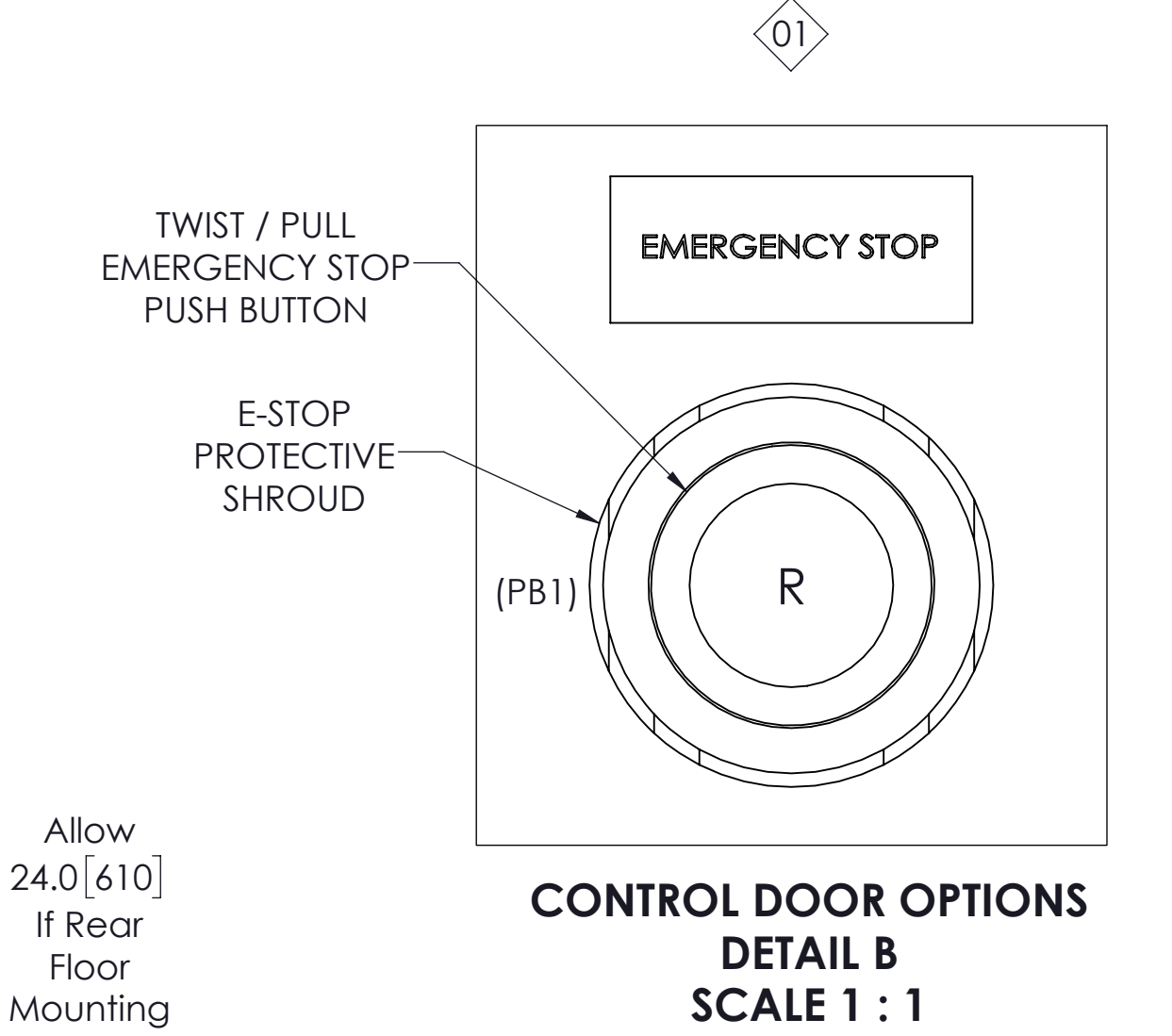
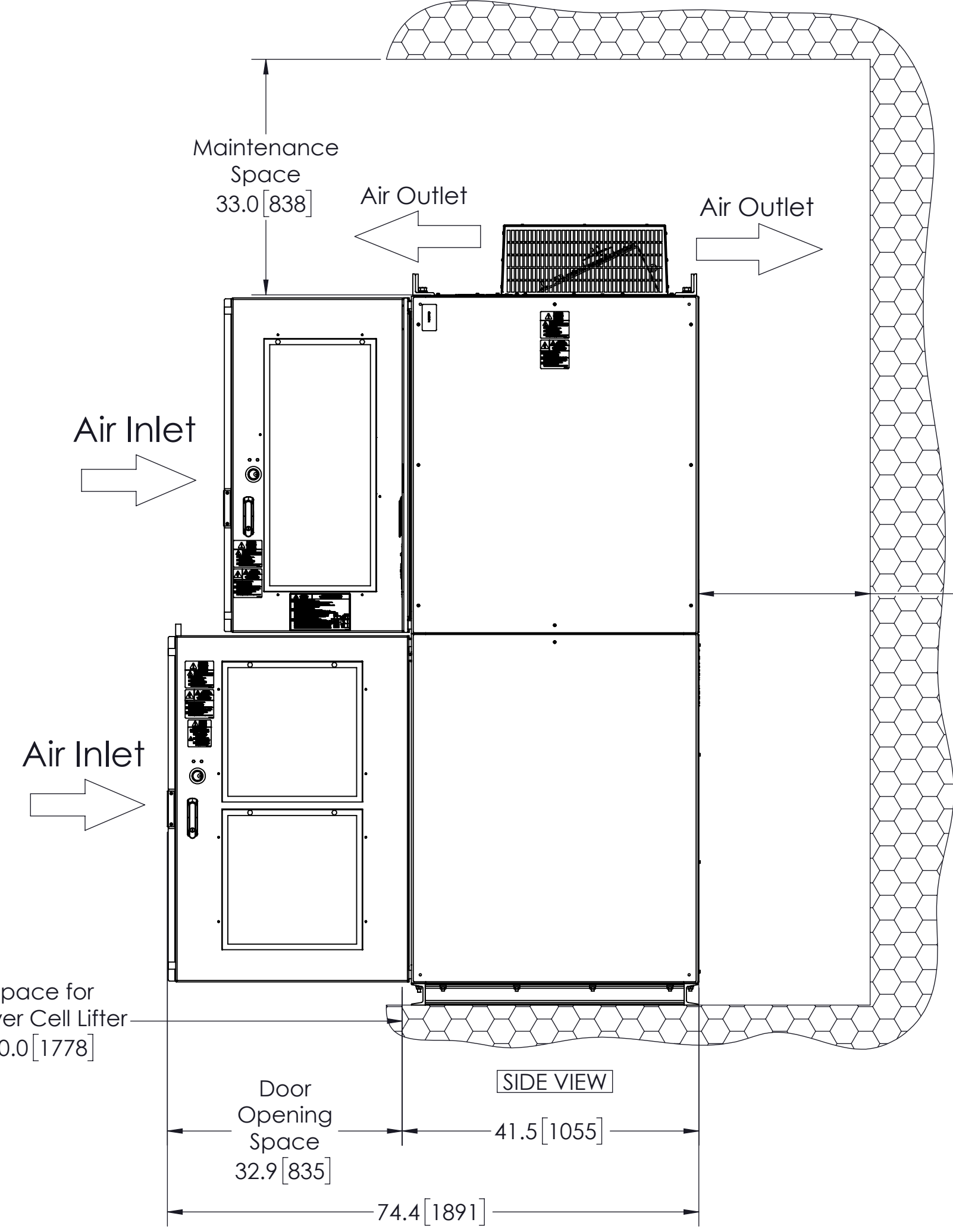
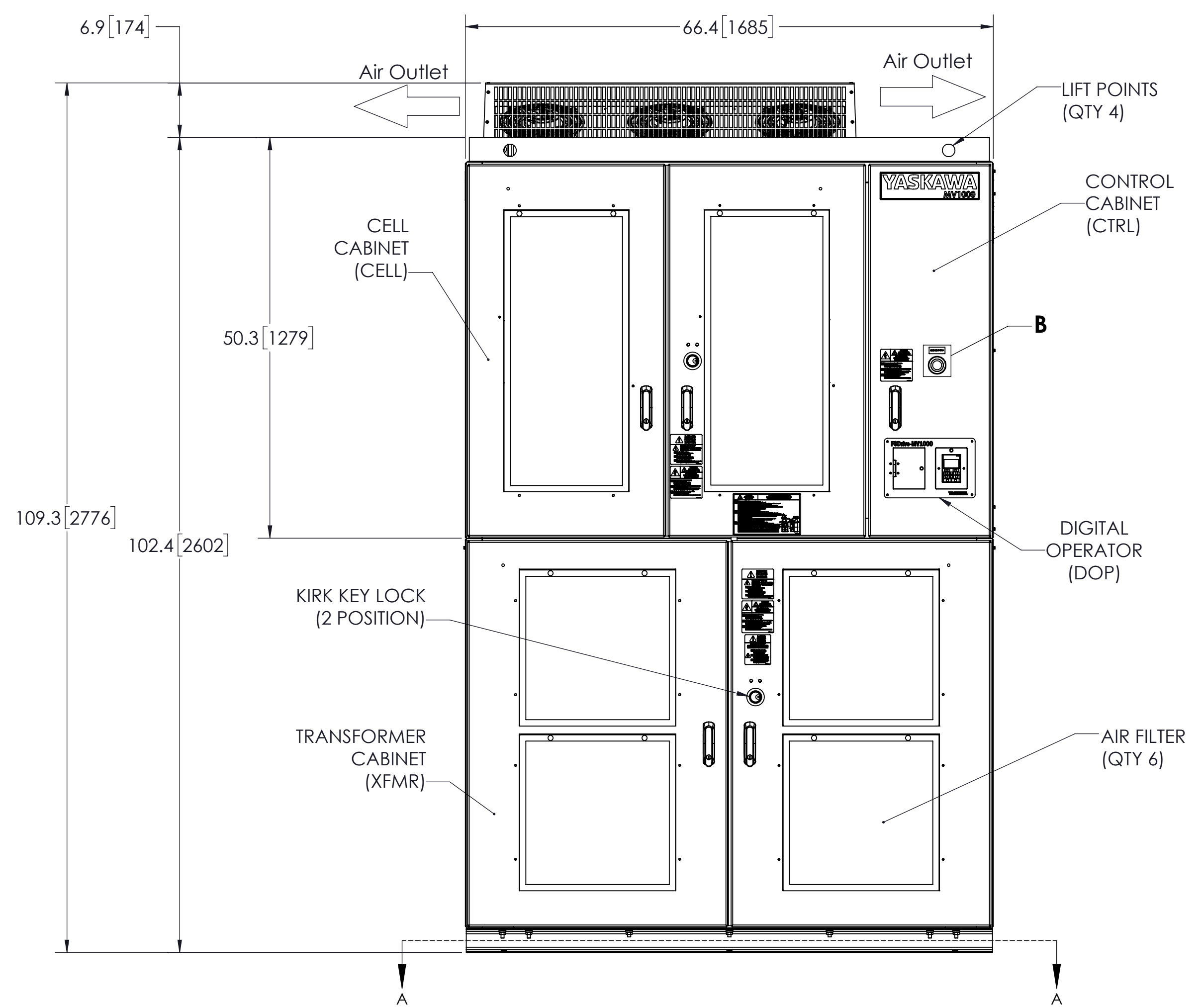
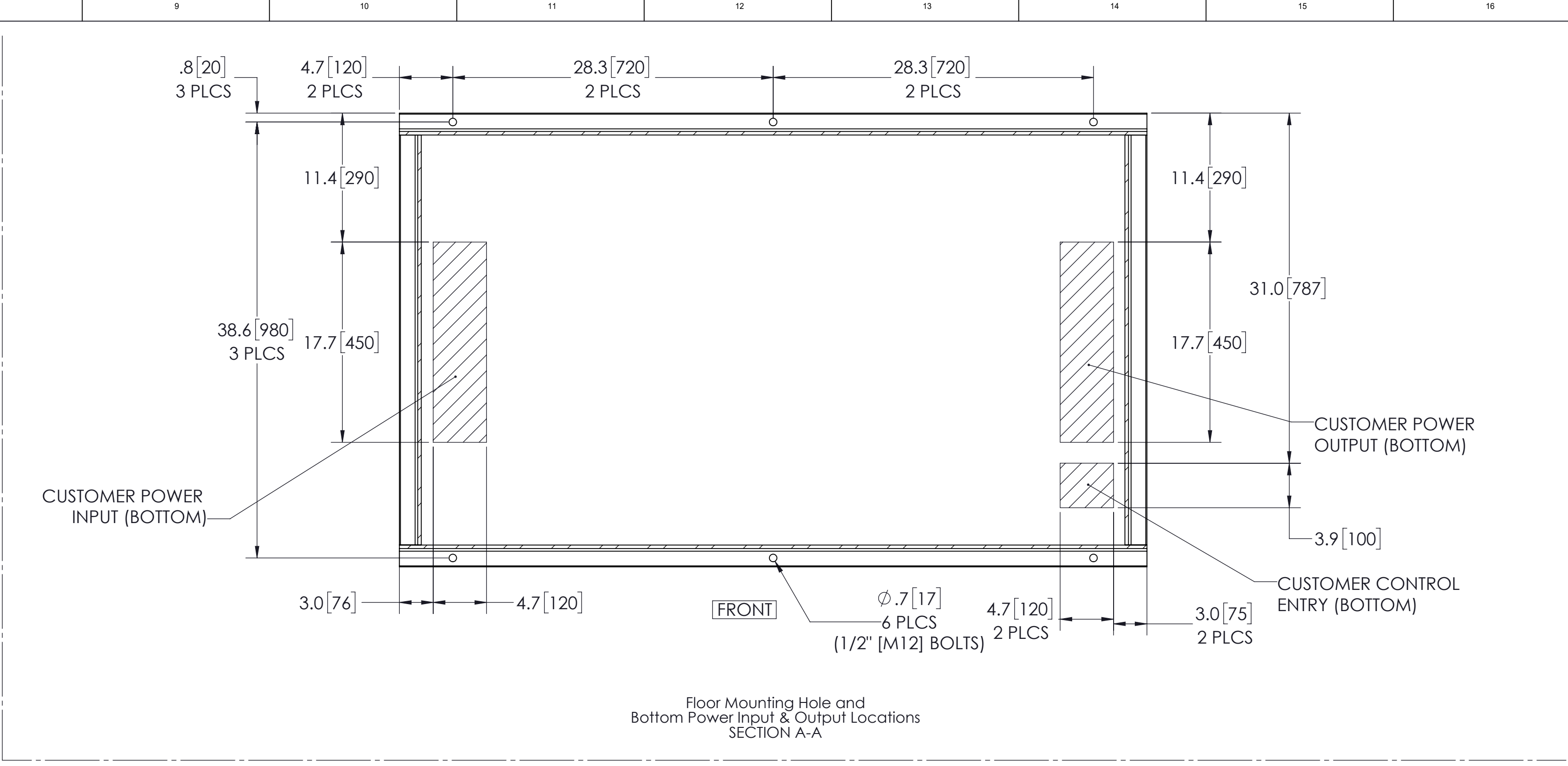
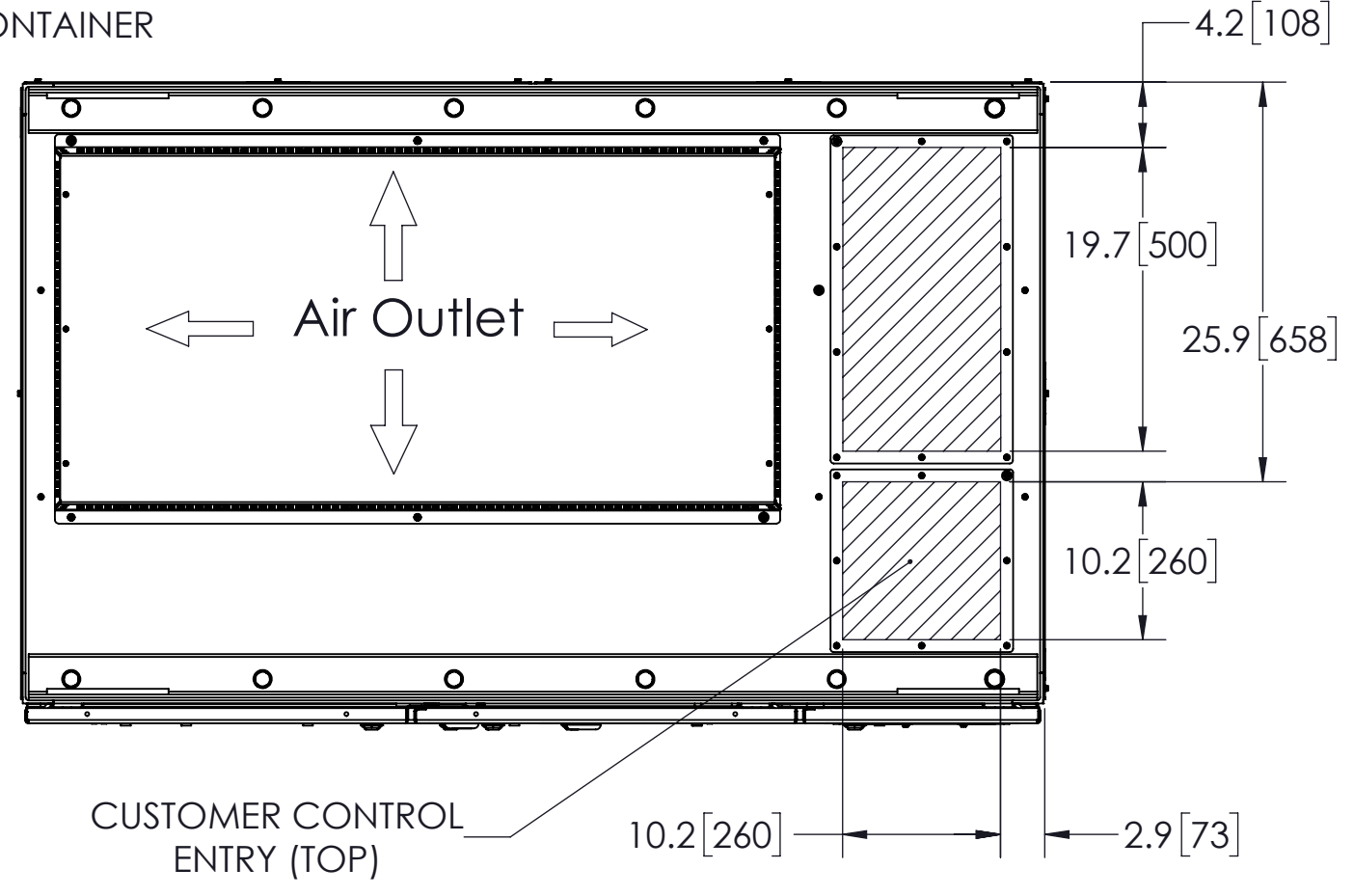

NOTES:  
 1. FOR REFERENCE UNLESS PROPERLY ENDORSED. FOR ADDITIONAL DETAILS AND SPECIFICATIONS, CONSULT YASKAWA AMERICA, INC.  
 2. DIMENSIONS ARE IN INCHES[MILLIMETERS]  
 3. USE APPROPRIATE TYPE RATED HUBS OR FITTINGS TO MAINTAIN ENCLOSURE RATING.  
 4. HATCHED AREA INDICATES PERMISSIBLE CABLE/CONDUIT ENTRANCE AREA.

REV.	DESCRIPTION	ECR#	DRAWN BY	DATE
01	<PG 1> ADDED E-STOP; <PG 2> ADDED REF. DESIGNATORS	8397	JSK	2/1/2018
00	INITIAL RELEASE	-	CJM	6/7/2016

jim\_kasproovich Tuesday, February 6, 2018 12:42:31 PM

ENCLOSURE	UL TYPE 1
COLOR	OUTSIDE: BEIGE, MUNSELL 5Y7/1 (SEMI GLOSS) INSIDE: BEIGE, MUNSELL 5Y7/1 (SEMI GLOSS)

ITEM NO.	NAME
(XFMR)	TRANSFORMER CABINET
(CELL)	CELL CABINET
(CTRL)	CONTROL CABINET

**YASKAWA**

DRAWN: C. Michalek	DATE: 6/7/2016	TITLE: DIMENSIONAL DRAWING, MV1000, FRM 1, W/O SG
CHECKED: S. Tomczak	DATE: 6/13/2016	
TECH: -	DATE: -	
APPROVED: B. Johnson	DATE: 6/28/2016	
ORIGINAL DESIGN: C. Michalek	DATE: 6/7/2016	

THIS DOCUMENT AND INFORMATION CONTAINED IN IT ARE CONFIDENTIAL, AND CANNOT BE COPIED OR DISCLOSED IN WHOLE OR IN PART WITHOUT THE EXPRESS WRITTEN CONSENT OF YASKAWA AMERICA INC.

MATERIAL#	SEE TABLE
SIZE D	REVISION 01
	PAGE 1 OF 2

DRAWING #: DD.MV1K.FR1.N1.NG.01

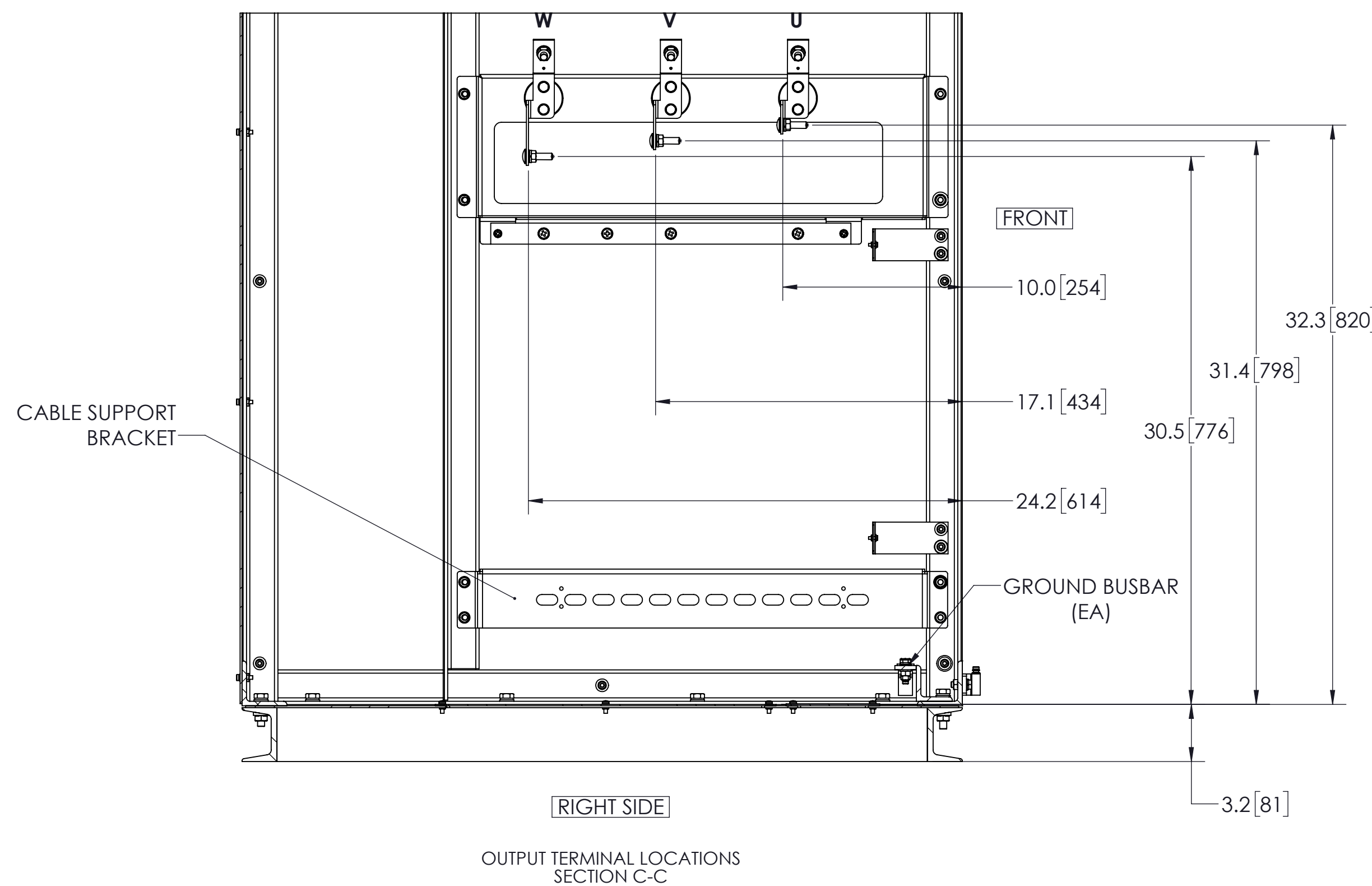
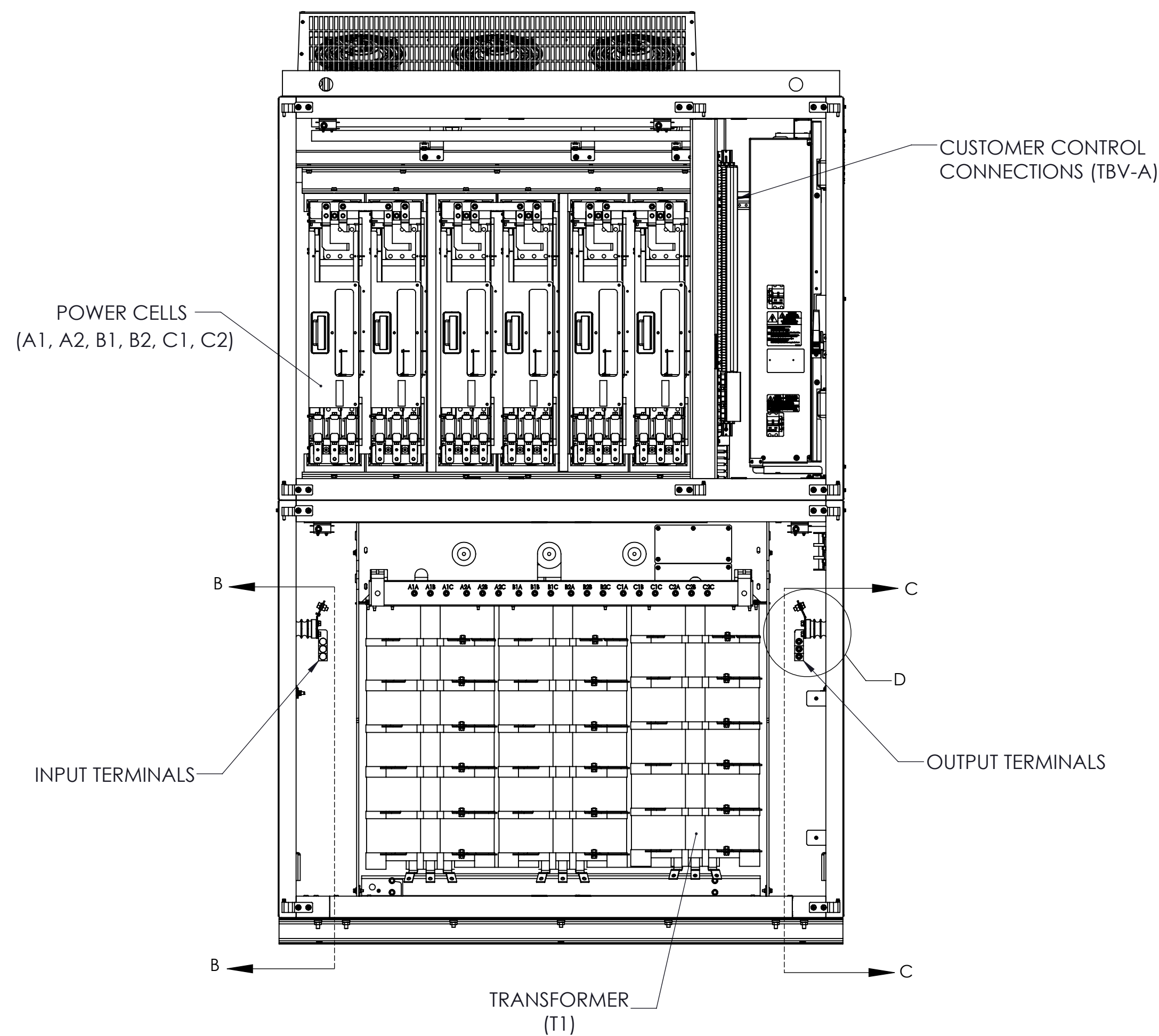
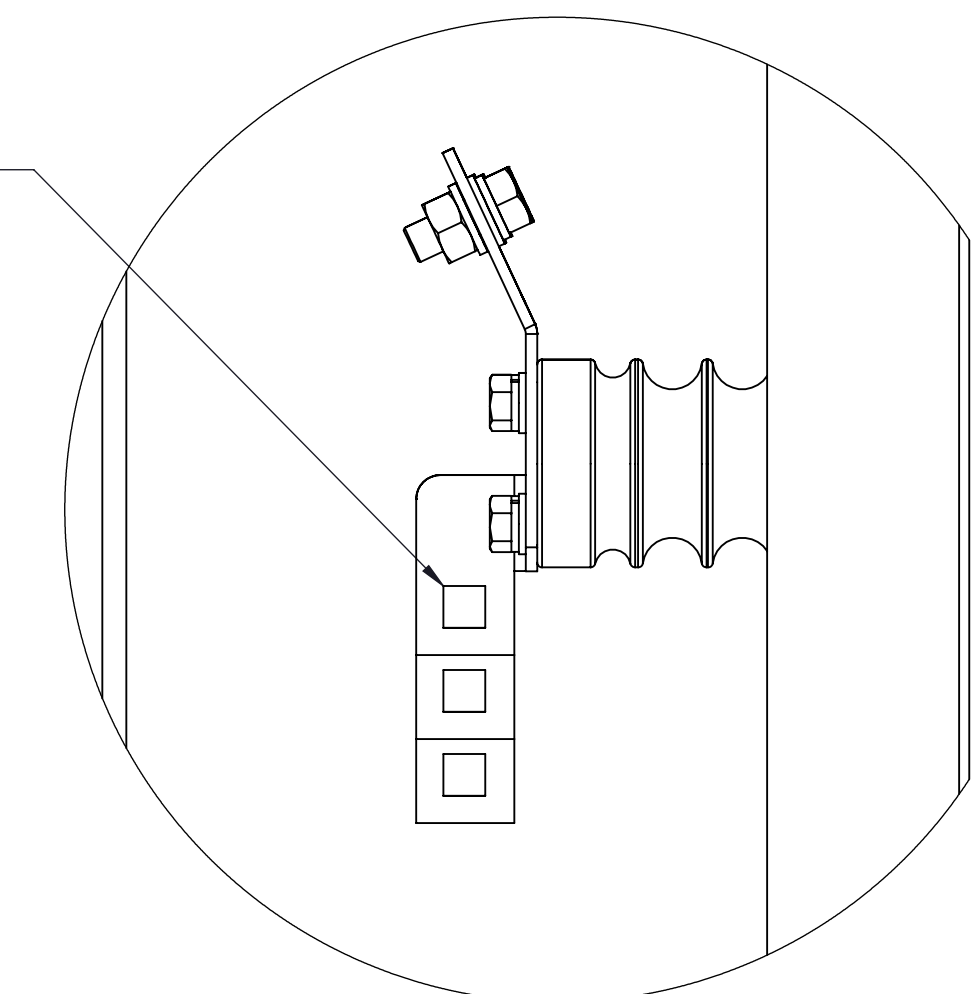
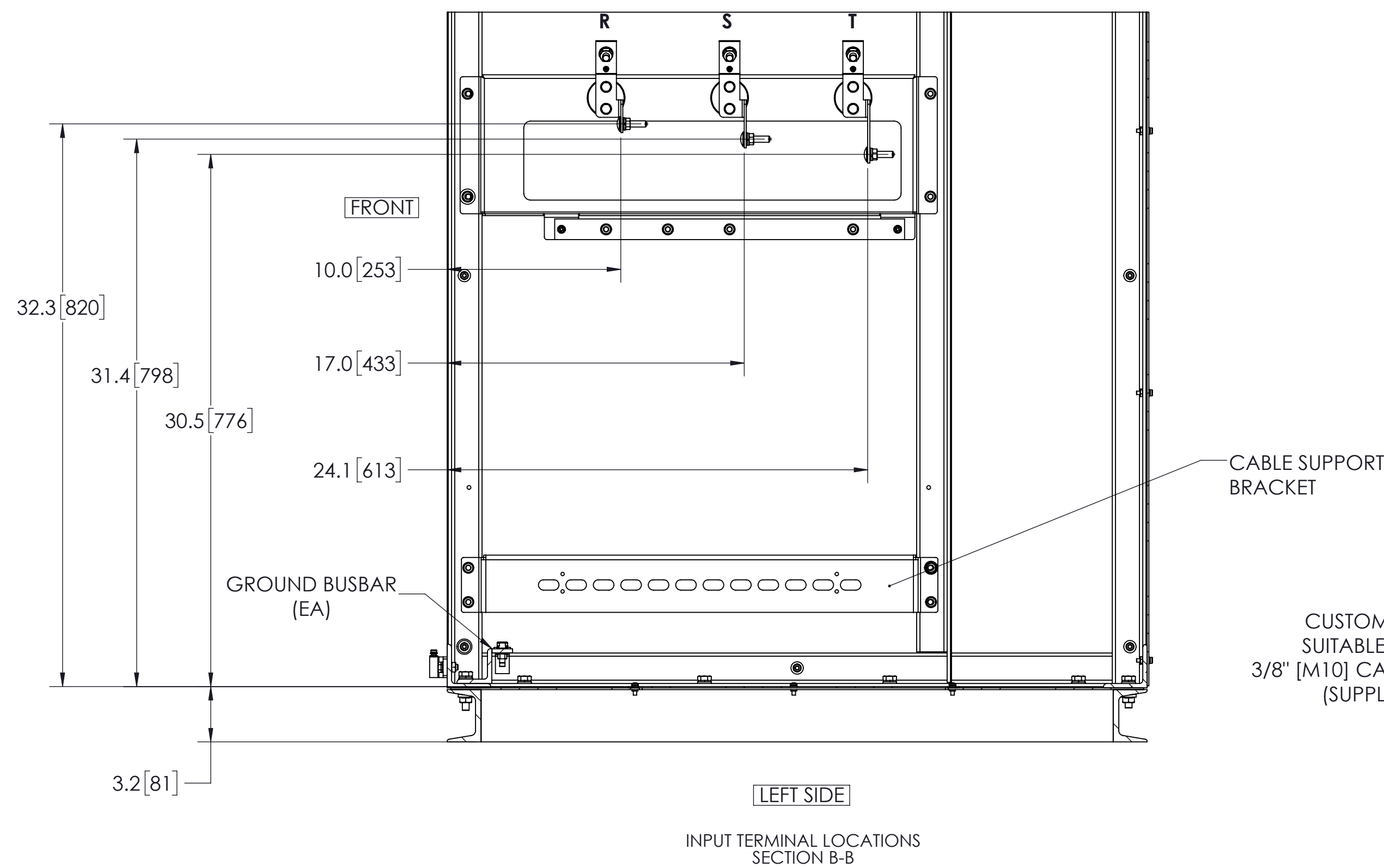
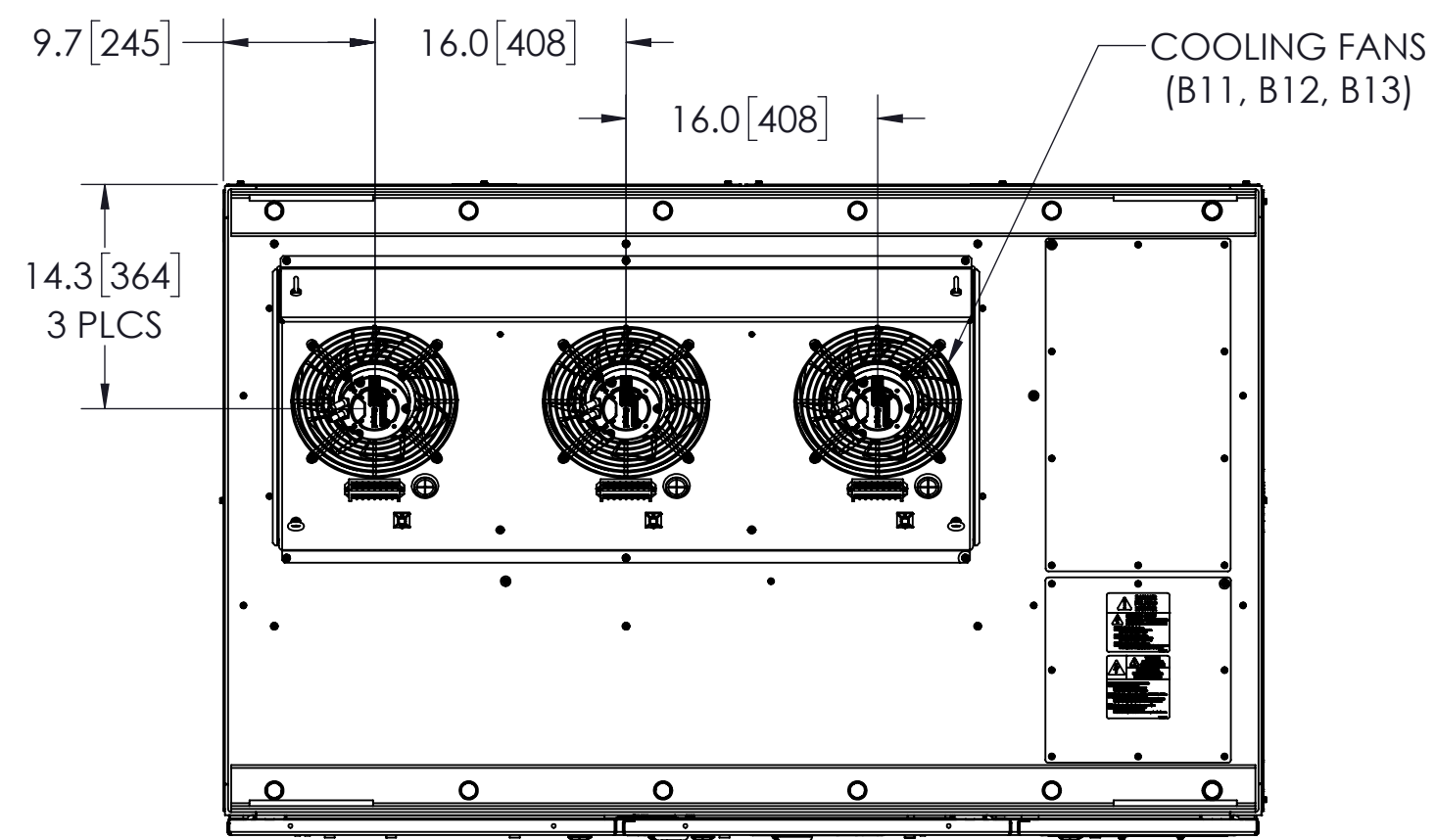

- NOTES:
- FOR REFERENCE UNLESS PROPERLY ENDORSED. FOR ADDITIONAL DETAILS AND SPECIFICATIONS, CONSULT YASKAWA AMERICA, INC.
  - DIMENSIONS ARE IN INCHES[MILLIMETERS]
  - USE APPROPRIATE TYPE RATED HUBS OR FITTINGS TO MAINTAIN ENCLOSURE RATING.
  - HATCHED AREA INDICATES PERMISSIBLE CABLE/CONDUIT ENTRANCE AREA.

<b>YASKAWA</b>		DRAWN: C. Michalek	DATE: 6/7/2016	TITLE: DIMENSIONAL DRAWING, MV1000, FRM 1, W/O SG	
		CHECKED: S. Tomczak	DATE: 6/13/2016		
		TECH: -	DATE: -	MATERIAL#	SEE TABLE
		APPROVED: B. Johnson	DATE: 6/28/2016	SIZE: D	REVISION: 01
		ORIGINAL DESIGN: C. Michalek	DATE: 6/7/2016	PAGE: 2 OF 2	
				DRAWING #: DD.MV1K.FR1.N1.NG.01	